

WIRELESS ELECTRO-INSTALLATION

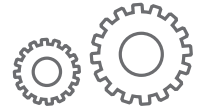

TECHNICAL CATALOGUE

RF



ELKO EP



We are traditional, innovative and purely Czech development manufacturer of electronic devices and we have been your partner in the field of electroinstallations for 27 years.

ELKO EP employs about 330 people, exports its products to more than seventy countries, and has representatives in fifteen foreign branches. Company of the Year of the Zlín Region, Visionary of the Year, Global Exporter of the Year, Participation in the Czech TOP 100, these are just some of the awards received. Still, we are not finished. We are constantly striving to move forward in the field of innovation and development. That's our primary concern.

Millions of relays, thousands of satisfied customers, hundreds of our own employees, twenty seven years of research, development and production, fifteen foreign branches, one company. ELKO EP, innovative- a purely Czech company based in Holešov, where development, production, logistics, service and support go hand in hand. We primarily focus on developing and manufacturing systems for building automation in the residential, commercial and industrial sector, a wide range of Smart city facilities and the so-called Internet of Things (IoT).



Facts and stats

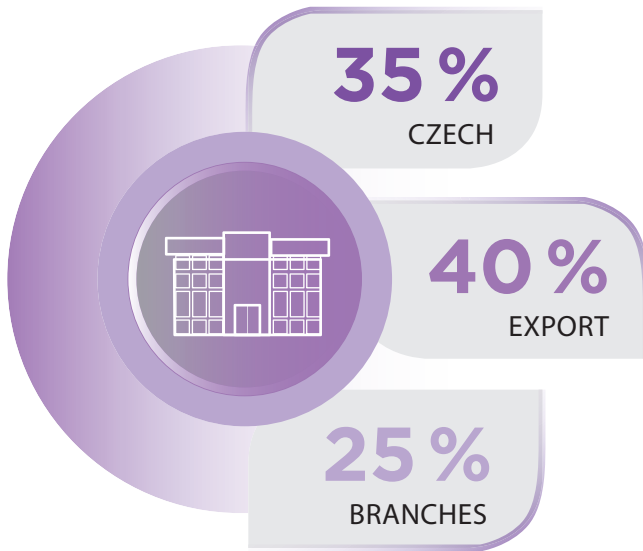

330
EMPLOYEES

15 000
iNELS INSTALLATION

12 000 000
MANUFACTURED PRODUCTS

6
FRANCHISES
OVER THE
WORLD

9
BRANCHES
OVER THE
WORLD

70
EXPORTING
COUNTRIES

2nd position
in Europe
with timers/time relays

WE ARE

DEVELOPERS

In the new R&D center, more than 30 engineers develop new products and extend the functionality of existing products

PRODUCERS

Modern antistatic spaces, 2x fully automated SMD production lines, 2 shift operations.

SUPPORT

24 hours / 7 days / 360 days we not only provide technical support but also logistics.

SELLERS

personal access to more than 70 sales representatives in ELKO EP Holding provides impeccable services and superior products at an affordable price.

Wireless control system

CLASSIC ELECTRO-INSTALLATION

www.elkoep.com/relays

Electricity is our everyday guide. In our range you will find electronic modular devices from time relays to thermostats. We build on solid foundations and have been developing and manufacturing for more than 27 years.

Price: Savings:



Switching appliances	Dimming lights	Controlling blinds	Heating regulation	Wireless controllers	Detectors	Smartphone Smart watch	Touch panel
Controlling household appliances	Door communicator	Weather station	Video cameras (outdoor/indoor)	Audio Zone (music playback)	PC/Laptop	Tablet	Video Zone (controlling via TV)

WIRELESS ELECTRO-INSTALLATION

www.elkoep.com/wireless

An ideal solution for completed houses, when it is no longer possible to intervene in the structure. Communication works wirelessly through the central brain, the RF Touch unit. From this unit you control thermostats and can control up to a range of 200 m.

Price: Savings:

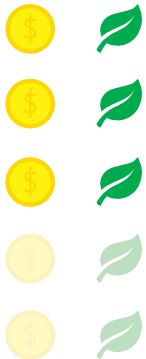

directly

integrated

Switching appliances	Dimming lights	Controlling blinds	Heating regulation	Wireless controllers	Detectors	LARA	Touch panel
Controlling household appliances	Door communicator	Weather station	Video cameras (outdoor/indoor)	A/C brands			

WIRED ELECTRO-INSTALLATION

www.elkoep.com/wired

If you are building a new house, this electrical installation is tailor-made for you. The data wire (bus) is routed in the walls through the entire house. The advantage is the possibility of expansion with a multimedia superstructure or connection of third parties (appliances, cameras, etc.)

Price: Savings:

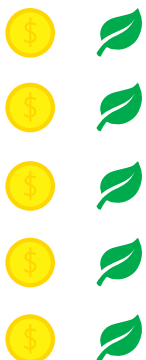

Switching appliances	Dimming lights	Controlling blinds	Heating regulation	Wireless controllers	Detectors	LARA	Touch panel
Controlling household appliances	Door communicator	Weather station	Video cameras (outdoor/indoor)	A/C brands			

It does not matter what you control, but how easily you control it. With us you can control the devices and appliances in many ways, one at a time or combine them at will.

For those conservatives amongst us, there are buttons in the form of switches exactly as we know and are used to them, for those of

us who often move around the house In the garden, the RF Pilot remote control in your pocket will surely be appreciated. Touch unit is again designed for those who like everything in one place with a – 3.5 „display securely holding all the necessary buttons within the frame. An interesting and often preferred option is the driver’s smartphone – which most of us already have in our pocket.

YOU CAN CONTROL iNELS WITH:



Wireless wall controller

- 2 or 4 buttons
- simple installation – can be attached or fixed anywhere
- in LOGUS⁹⁰ design (natural materials and colour combinations)

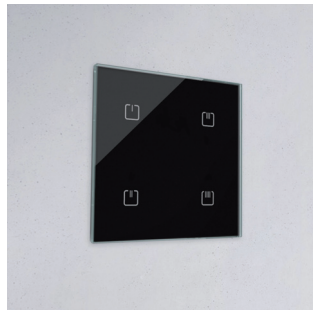

Touch glass controller

- wall controller in elegant glass design
- 2 or 4 buttons
- two side tape installation or wall box installation
- signal range up to 200 m



Wireless touch unit RF Touch

- wireless touch unit for wall box installation
- it will become a central, wireless intuitively controlled home
- coloured 3,5" TFT display



Keychain

- 4 button controller
- pocket controller for every day
- in colour white or black



Remote controller with display

- here marks the start of home automation
- the remote controller with OLED colour display offers control of up to 40 household appliances
- lights, sockets, garage doors, sprinklers, blinds, awnings, etc.

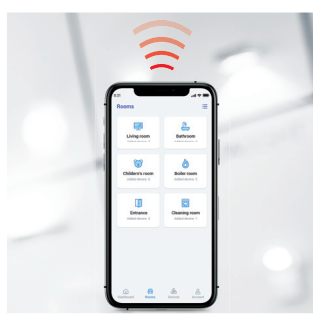

Smartphone

- the only controller that comes free
- your home under control thanks to Android application
- you no longer have to worry about unpleasant surprises after downloading the Android or iOS application for free



Smart watch

- the only controller that comes free
- your home under control thanks to Android application
- you no longer have to worry about unpleasant surprises after downloading the Samsung Gear app



Smart TV SAMSUNG

- first application in the world for controlling iNELS in Samsung TV
- free download on Samsung Hub
- comfortably control not only the elements in individual rooms, but also outdoor cameras

iNELS RF Control: units overview	8
Controllers	
RFWB-20/G, RFWB-40/G On-wall button controllers	14
RFOWB-20 Outdoor controller, 2 buttons – (IP65) - NEW!	15
RFGB-20/W, RFGB-20/B, RFGB-40/W, RFGB-40/B Glass touch controllers, SHARP - NEW!	16
RFGB-220/W, RFGB-220/B, RFGB-240/W, RFGB-240/B Glass touch controllers, ROUND - NEW!	17
RFDW-71/W, RFDW-71/B Glass touch controller with dimmer, SHARP - NEW!	18
RFDW-271/W, RFDW-271/B Glass touch controller with dimmer, ROUND - NEW!	19
RF KEY-40/W, RF KEY-40/B, RF KEY-60/W, RF KEY-60/B Controller – key fob - NEW!	21
RF Pilot/W, RF Pilot/B Remote RF controller with display	22
Switches	
RFSA-11B, RFSA-61B Switch unit, 1-channel – (BOX)	24
RFSA-62B Switch unit, 2-channels – (BOX)	25
RFSAI-62B Switch unit, 2-channels with external input – (BOX)	26
RFJA-32B Switch unit for shutters – (BOX)	27
RFSA-61MI, RFSA-61M Switching units, 1-channel – (1-MODULE) - NEW!	28
RFSA-66MI, RFSA-66M Switching units, 6-channels – (3-MODULE) - NEW!	29
RFUS-61 Switch unit with increased protection	30
RFSC-61 Switching socket-plug	31
RFOSC-61 Switching sockets with increased protection – (IP65) - NEW!	32
Dimmers	
RFDEL-71B Universal dimmer, 1-channel – (BOX)	33
RFDAC-71B Analog controller, 0(1)-10 V – (BOX)	34
RFDEL-71M Universal dimmer, 1-channel – (3-MODULE)	35
RFDEL-76M Universal dimmer, 6-channels – (6-MODULE) - NEW!	36
RFDA-73M/RGB Dimmer for LED (RGB) strips, 3-channels – (3-MODULE)	38
RFDSC-71 Dimming socket-plug	40
Temperature control	
RFTC-10/G Simple temperature controller – (LOGUS ⁹⁰)	41
RFTC-50/G Autonomous temperature controller – (LOGUS ⁹⁰)	42
RFSTI-11B Switch unit with a external temperature sensor – (BOX)	43
RFTI-10B Temperature sensor – (BOX)	44
TC, TZ Temperature sensors	45
TELVA-2 230V, TELVA-2 24V Thermodrive	46
Converters	
RFIM-20B, RFIM-40B Input contacts converter – (BOX)	47
RFSG-1M Input contact converter (1-MODULE)	48
Detectors	
RFSF-1B Level switch – (BOX)	50
FP-1 Liquid probe	50
RFSF-100 Flood detector	51
RFSOU-1 Twilight switch – (IP65)	52
RFMD-100 Motion detector	53
RFWD-100 Window/door detector	54

System units

RF Touch | Wireless touch unit 56

RFRP-20 | Repeater to extend the range 58

eLAN-RF-103, eLAN-RF-Wi-103 | Smart RF gateway - **INNOVATION!** 59

Hotel Retrofit (HRESK)

RFTC-150/G | Temperature controller – (LOGUS⁹⁰) 61

RFSAI-161B | Lighting control unit with pair detectors and external button input – (BOX) 62

RFSTI-111B | Overheating/overcooling switch unit with advanced functions – (BOX) 64

RFS-166M | Switch unit for fancoil, 6-channels – (3-MODULE) 65

Applications 66

Voice assistants 67

Accessories

AN-I | Internal antenna 68

Extension cable for external antenna - **NEW!** 68

AN-E3 | External antenna - **NEW!** 68

AN-E1 | External antenna 69

RFAF/USB | Service Key 70

Supported video cameras, Supported intercoms 71

RF Sets 73

Overview of functions

Switches 74

Dimmers 75

Protocol and compatibility 76

Installation possibilities 77

Product dimension 78

EAN codes 82

Controllers

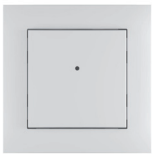
**RFWB-20/G**

On-wall button controller
- 2 buttons

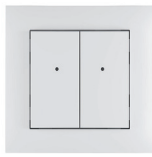
**RFWB-40/G**

On-wall button controller
- 4 buttons

**RFOWB-20**

Outdoor controller
- 2 buttons

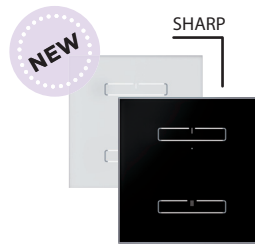

RFGB-20/W - white glass
RFGB-20/B - black glass
Glass touch controller, SHARP
- 2 buttons

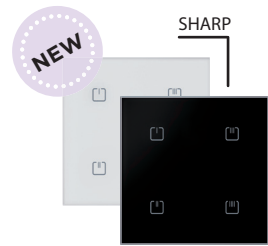

RFGB-40/W - white glass
RFGB-40/B - black glass
Glass touch controller, SHARP
- 4 buttons



RF KEY-40/W - white
RF KEY-40/B - black
Controller - key fob
- 4 buttons



RF KEY-60/W - white
RF KEY-60/B - black
Controller - key fob
- 6 buttons



RF Pilot/W - white
RF Pilot/A - anthracite
Remote RF controller with display

Switches

**RFS-A-11B**

Switch unit, 1-channel
- 1x 16 A, singlefunction

**RFS-A-61B**

Switch unit, 1-channel
- 1x 16 A, multifunction

**RFS-A-62B**

Switch unit, 2 channels
- 2x 8 A, multifunction

**RFS-AI-62B**

Switch unit, 2-channels
with external input

**RFS-A-32B**

Switch unit for shutters
- 2x 8 A

Dimmers

**RFDAC-71B**

Analog controller, 0(1)-10 V
- multifunction

**RFDEL-71B**

Universal dimmer,
1-channel - 1x 160 VA
- R, L, C, LED, ESL

**RFDEL-71M**

Universal dimmer,
1-channel - 1x 600 VA
- R, L, C, LED, ESL

**RFDEL-76M**

Universal dimmer,
6-channels
- 6 x 150 VA

**RFDA-73M/RGB**

Dimmer for LED (RGB)
strips, 3-channels

Temperature control

**RFTC-10/G**

Simple temperature
controller

**RFTC-50/G**

Autonomous temperature
controller

**RFSTI-11B**

Switch unit with an external
temperature sensor

**RFTI-10B**

Temperature sensor
(internal + external)

**TC TZ**

Temperature sensors



RFGB-220/W - white glass
RFGB-220/B - black glass
 Glass touch controller, ROUND
 - 2 buttons

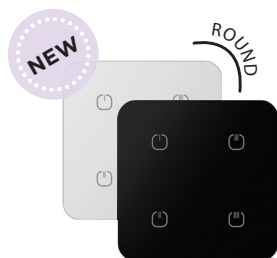

RFGB-240/W - white glass
RFGB-240/B - black glass
 Glass touch controller, ROUND
 - 4 buttons

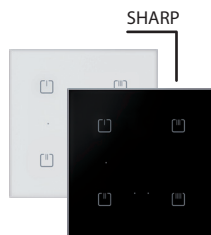

RFDW-71/W - white glass
RFDW-71/B - black glass
 Glass touch controller
 with dimmer, SHARP

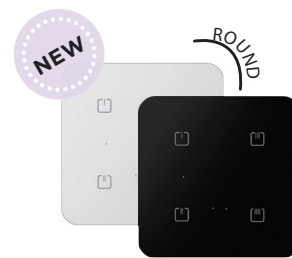

RFDW-271/W - white glass
RFDW-271/B - black glass
 Glass touch controller
 with dimmer, ROUND



RFSA-61M **RFSA-61MI**
 Switching units, 1-channel
 - multifunction, 1x 16 A



RFSA-66M **RFSA-66MI**
 Switching units, 6-channels
 - multifunction, 6x 8 A



RFUS-61
 Switch unit with
 increased protection,
 1x 12 A, multifunction



RFSC-61
 Switching socket-plug,
 - 1x 16 A, multifunction



RFOSC-61
 Switching sockets with
 increased protection



RFDSC-71
 Dimming socket-plug
 - 1x 300 VA
 - R, L, C, LED, ESL



TELVA-2
 Thermoswitch
 ON/OFF, 0-10V

Converters



RFIM-20B
Input contacts converter
– 2x permanent contacts



RFIM-40B
Input contacts converter
– 4x instantaneous contacts



RFSG-1M
Input contact converter
– 1x permanent contact

Detectors



RFSF-1B
Level switch



FP-1
Liquid probe

System units



RF Touch-B
Wireless touch unit
– flush mounted



RF Touch-W
Wireless touch unit
– on the wall



eLAN-RF-103
Smart RF gateway
with LAN



eLAN-RF-Wi-103
Smart RF gateway
with LAN & WiFi



RFRP-20
Repeater to extend
the range

Hotel Room Energy Saving Kit



RFTC-150/G
Temperature
controller



RFSAI-161B
Lighting control unit
with pair detectors
and external button input



RFSTI-111B
Overheating/overcooling
switch unit with advanced
functions



RFSA-166M
Switch unit for fancoil,
6-channels

Accessories



RFAF/USB
Service Key



AN-I
Internal antenna
Gain: 2.1 dBi



AN-E
External antenna
Gain: 5 dBi



AN-E3
External antenna
Gain: 3 dBi, IP67



Extension cable for
external antenna
10 m

Supported video cameras



Protocols MJPEG, RTSP, ONVIF

Supported intercoms



2N

HIK VISION



RFSF-100
Flood detector



RFSOU-1
Twilight switch



RFWD-100
Window/Door detector



RFMD-100
Motion detector

INELS®

RF Control

 **RFIO** - radiofrequency protocol unidirectional
RFIO2 - radiofrequency protocol bidirectional

 **Wi-Fi**

 **LAN**

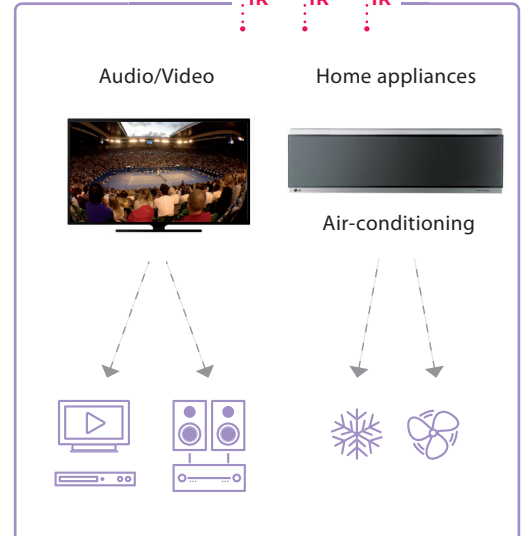
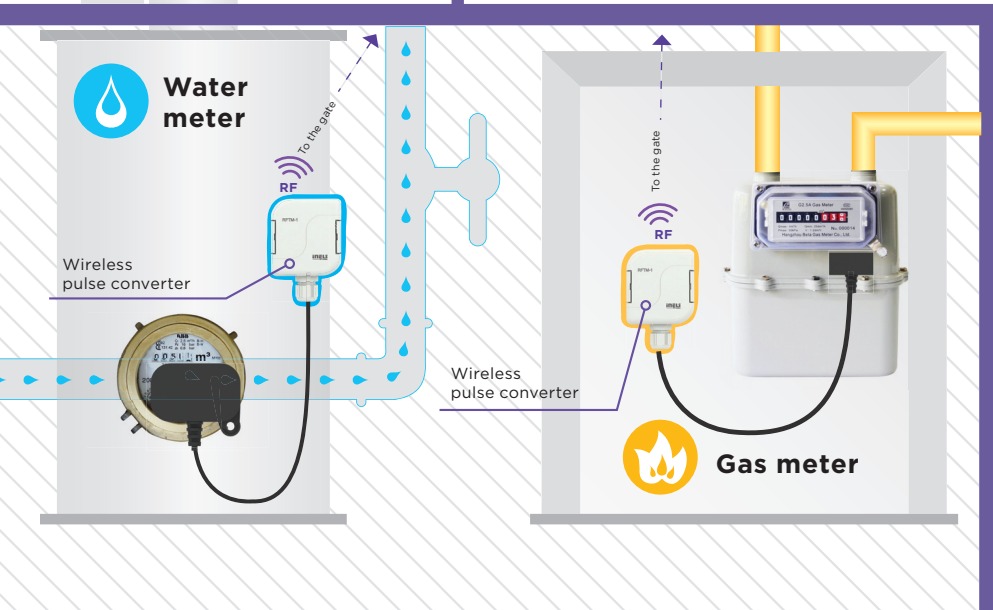
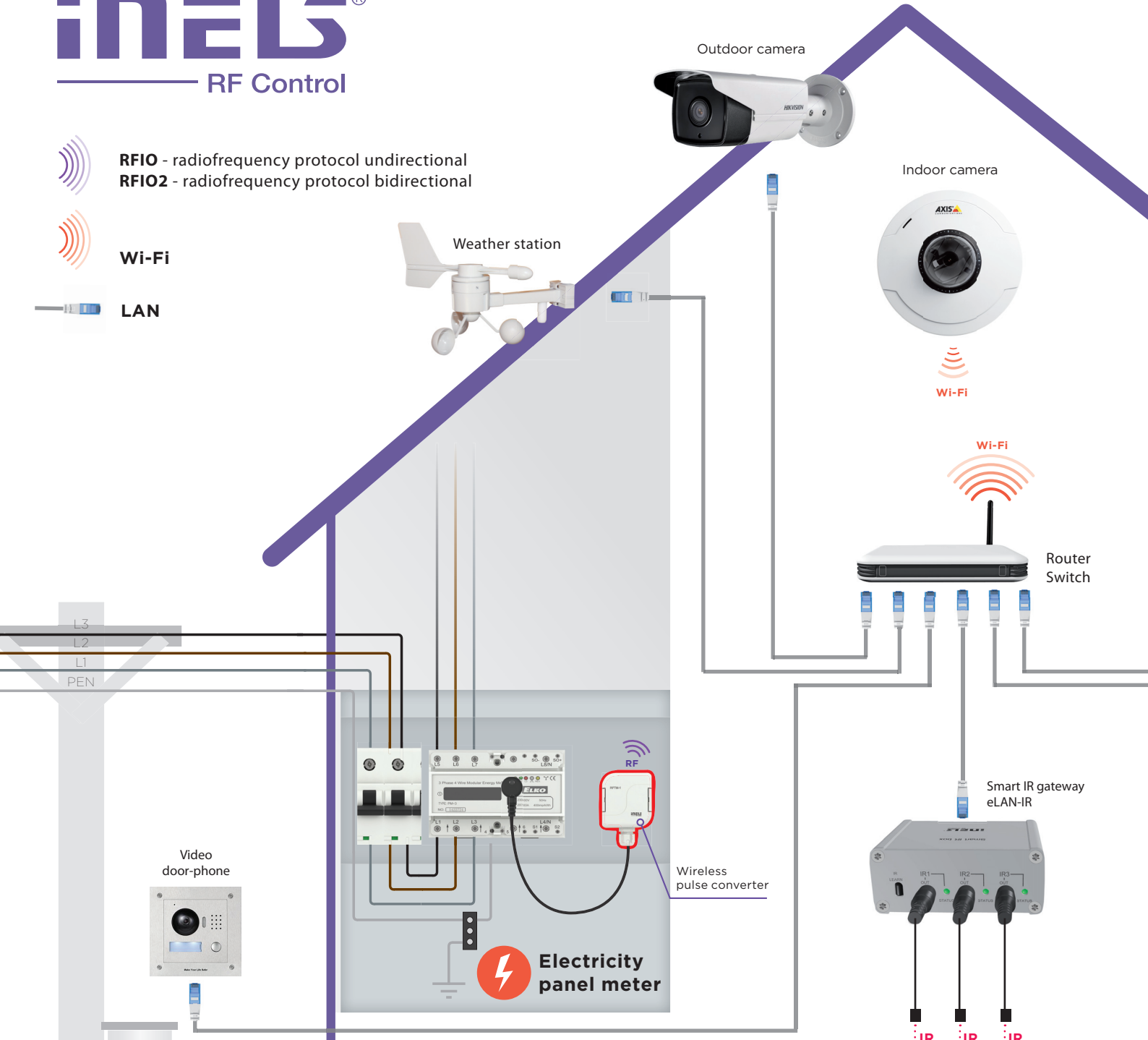

External Controllers:

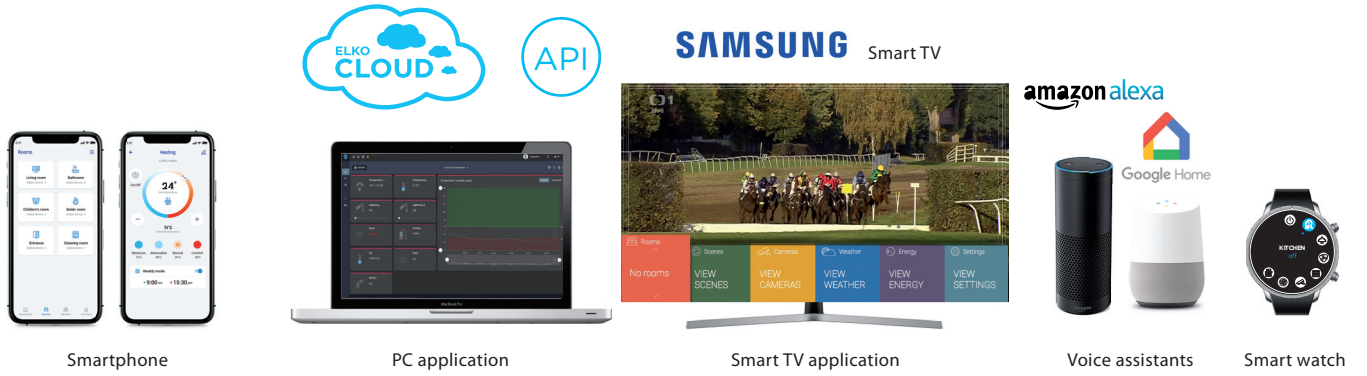

Internal Controllers:

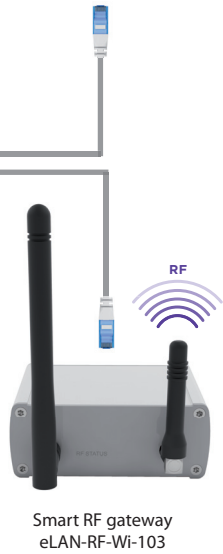

Detectors:

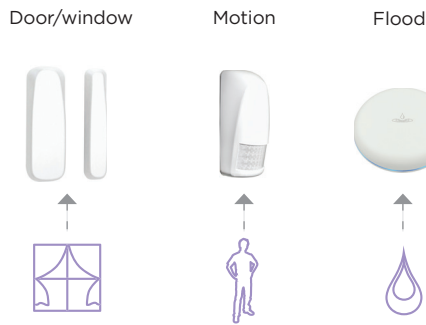

Sensors:

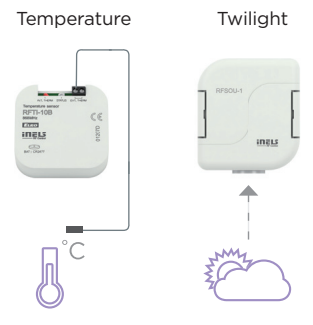

Units:

Switch unit
- 6 outputs

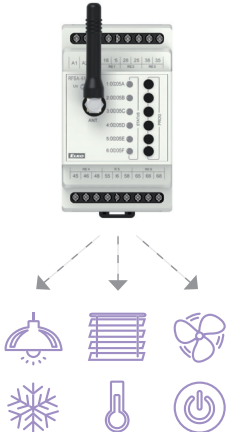

Switch unit
to installation
box



Switching
socket



Switch unit
for shutters



Switch unit
- 1-channel



Dimmer for
LED strips





- On-wall button controller is used to control switches and dimmers (lights, gate, garage door, blinds, etc.).
- **RFWB-20/G**: two buttons enable control of two units independently.
- **RFWB-40/G**: four buttons enable control of four units independently.
- The flat design with level base makes it ideal for fast installation on any surface (fixation with adhesive or screws in the installation box).
- When pressing the button, it sends a set signal (ON/OFF, dimming, time switching OFF/ON, blinds up/down).
- Sending a command is indicated by a red LED.
- In LOGUS⁹⁰ switch frame design (plastic, glass, wood, metal, stone).
- Option of setting light scenes, where with a single press, you can control units of iNELS RF Control.
- Battery power supply (3 V CR 2032 battery - included in the supply) with battery life of around 5 years based on frequency of use.
- Range up to 200 m (in open space), if the signal is insufficient between the controller and unit, use the signal repeater RFRP-20 or protocol component RFIO2 that support this feature.
- Communication frequency with bidirectional protocol RFIO2.
- RFWB enables communication (RFIO2) and can thus communicate with the CU3-02M.

Technical parameters	RFWB-20/G	RFWB-40/G
Supply voltage:	3 V CR 2032 battery	
Battery life:	around 5 years based on frequency of use	
Transmission indication:	red LED	
Number of buttons:	2	4
Communication protocol:	RFIO2	
Frequency:	866–922 MHz (for more information see p. 76)	
Signal transmission method:	unidirectionally addressed message	
Range:	in open space up to 200 m	
Other data		
Operating temperature:	-10 to +50 °C	
Operating position:	any	
Mounting:	glue/screws	
Protection:	IP20	
Contamination degree:	2	
Dimensions frame		
- plastic:	85 x 85 x 16 mm	
- metal, glass, wood, granite:	94 x 94 x 16 mm	
Weight (plastic):*	38 g	39 g
Related standards:	EN 60669, EN 300 220, EN 301 489 R&TTE Directive, Order. No 426/2000 Coll. (Directive 1999/EC)	

Device description

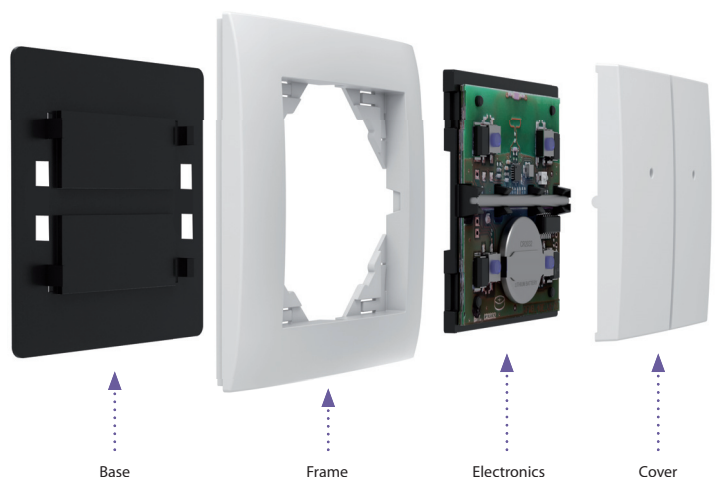
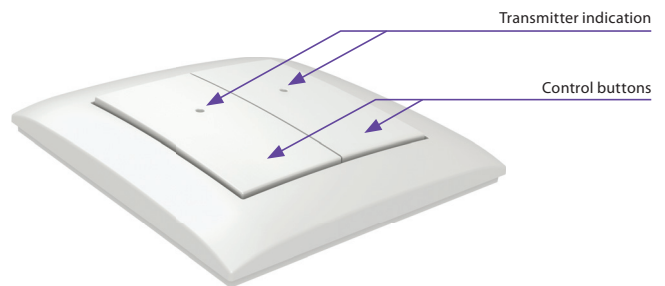

LOGUS⁹⁰

Choose your own style

Flat wireless switches that can be mounted on glass, tile, furniture ...
Such a quick change of location when you're moving.

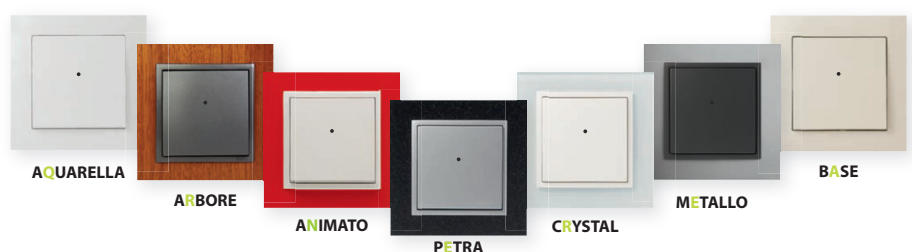



- The wireless push-button controller with IP65 protection is used to control iNELS RF components and protect them from the outdoor environment.
- 2 buttons allow (independently of each other) control of an unlimited number of components (actuators).
- The controller is suitable for control from the pool, garden, terrace, and pergola. It can be used as an uncovered bell button.
- Fastening with screws or double-sided tape.
- Battery power supply (3 V CR 2032 battery - included in the supply) with battery life of around 5 years based on frequency of use.

Technical parameters	RFOWB-20
Supply voltage:	3 V CR 2032 battery
Battery life:	around 5 years based on frequency of use
Transmission indication:	Integrated red LED
Number of buttons:	2
Communication protocol:	RFIO2
Frequency:	866–922 MHz (for more information see p. 76)
Signal transmission method:	unidirectionally addressed message
Range:	in open space up to 200 m
Other data	
Operating temperature:	-10 to +50 °C
Mounting:	screws/double sided tape
Colour design:	white (RAL 9003)
Protection:	IP65
Contamination degree:	2
Dimensions frame:	64 x 74 x 44 mm
Weight:	112 g
Related standards:	EN 60669, EN 300 220, EN 301 489 R&TTE Directive, Order. No 426/2000 Coll. (Directive 1999/EC)

Device description

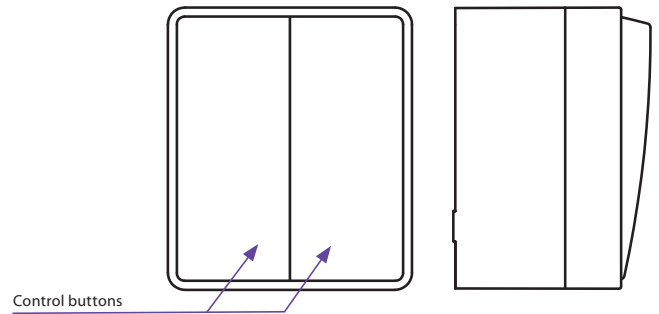

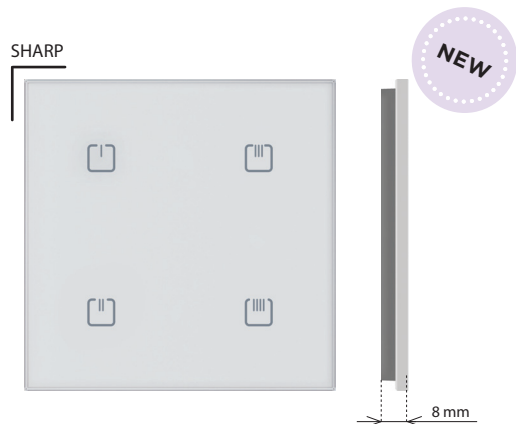

- The glass touch controller is a design RF (wireless) Control unit and is available in elegant black and white variants.
- Only 8 mm thick.
- **RFGB-20:** 2 capacitive buttons allows to control 2 devices.
- **RFGB-40:** 4 capacitive buttons allows to control 4 devices.
- When pressing the button, it sends a set signal (ON/OFF, dimming, time switching OFF/ON, blinds up/down). Sending a command is indicated by a red LED.
- Option of setting light scenes, where with a single press, you can control units of iNELS RF Control.
- The rear base allows to be attached to installation using screws, double-sided tape or keeping controller on the table.
- Battery power supply (2x 3 V CR 2032 batteries - included in the supply) with battery life of around 2 years based on frequency of use.
- Range up to 200 m (in open space), if the signal is insufficient between the controller and unit, use the signal repeater RFRP-20 or protocol component RFIO2 that support this feature.
- Communication frequency with bidirectional protocol RFIO.

Technical parameters	RFGB-20	RFGB-40
Supply voltage:	2x 3 V CR 2032 batteries	
Battery life:	around 2 years based on frequency of use	
Transmission indication:	red LED	
Number of capacitive buttons:	2	4
Communication protocol:	RFIO	
Frequency:	866–922 MHz (for more information see p. 76)	
Signal transmission method:	unidirectionally addressed message	
Range:	in open space up to 200 m	
Other data		
Operating temperature:	-10 to +50 °C	
Operating position:	any	
Mounting:	glue/screws	
Protection:	IP20	
Contamination degree:	2	
Dimensions:	94 x 94 x 8 mm	
Weight:	107 g	107 g
Related standards:	EN 60669, EN 300 220, EN 301 489 R&TTE Directive, Order. No 426/2000 Coll. (Directive 1999/EC)	

Device description

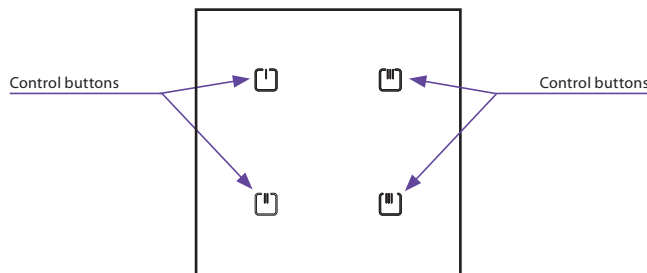

RFGB-40/W

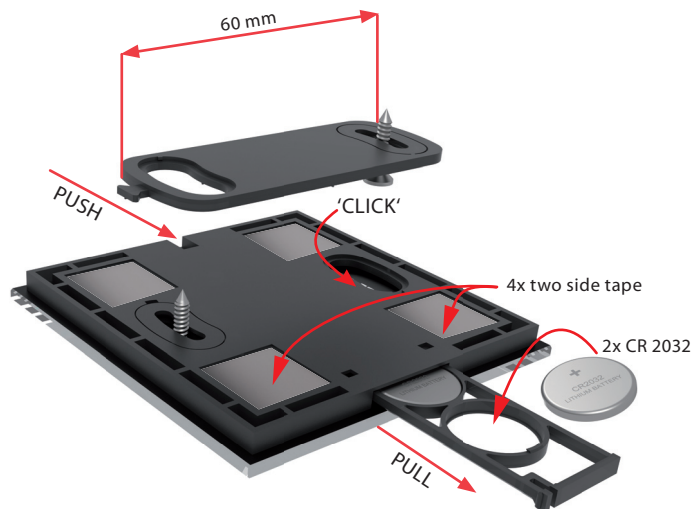
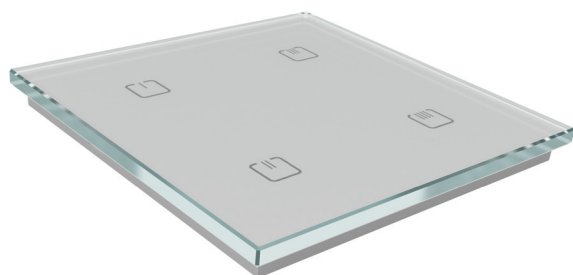

Variants



RFGB-20/W

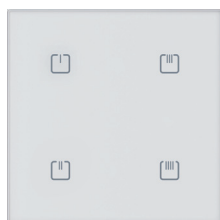

RFGB-40/W

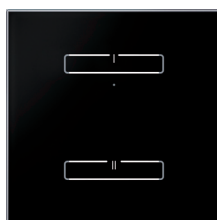

RFGB-20/B



RFGB-40/B

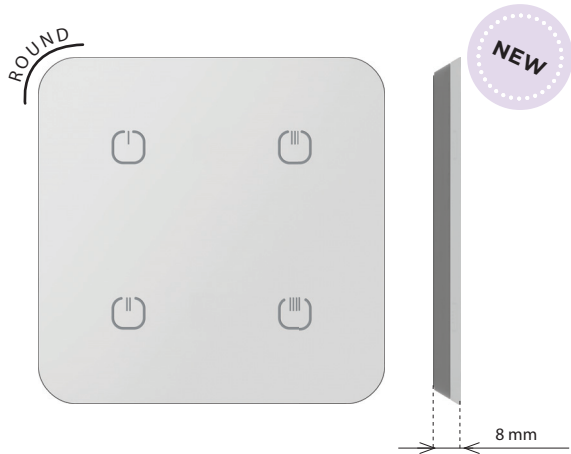

- The glass touch controller is a design RF (wireless) Control unit and is available in elegant black and white variants.
- Only 8 mm thick.
- **RFGB-220:** 2 capacitive buttons allows to control 2 devices.
- **RFGB-240:** 4 capacitive buttons allows to control 4 devices.
- When pressing the button, it sends a set signal (ON/OFF, dimming, time switching OFF/ON, blinds up/down). Sending a command is indicated by a red LED.
- Option of setting light scenes, where with a single press, you can control units of iNELS RF Control.
- The rear base allows to be attached to installation using screws, double-sided tape or keeping controller on the table.
- Battery power supply (2x 3 V CR 2032 batteries - included in the supply) with battery life of around 2 years based on frequency of use.
- Range up to 200 m (in open space), if the signal is insufficient between the controller and unit, use the signal repeater RFRP-20 or protocol component RFIO2 that support this feature.
- Communication frequency with bidirectional protocol RFIO.

Technical parameters	RFGB-220	RFGB-240
Supply voltage:	2x 3 V CR 2032 batteries	
Battery life:	around 2 years based on frequency of use	
Transmission indication:	red LED	
Number of capacitive buttons:	2	4
Communication protocol:	RFIO	
Frequency:	866–922 MHz (for more information see p. 76)	
Signal transmission method:	unidirectionally addressed message	
Range:	in open space up to 200 m	
Other data		
Operating temperature:	-10 to +50 °C	
Operating position:	any	
Mounting:	glue/screws	
Protection:	IP20	
Contamination degree:	2	
Dimensions:	100 x 100 x 8 mm	
Weight:	108 g	108 g
Related standards:	EN 60669, EN 300 220, EN 301 489 R&TTE Directive, Order. No 426/2000 Coll. (Directive 1999/EC)	

Device description

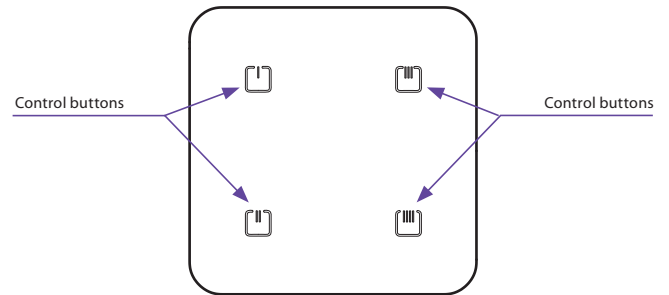

RFGB-240/W

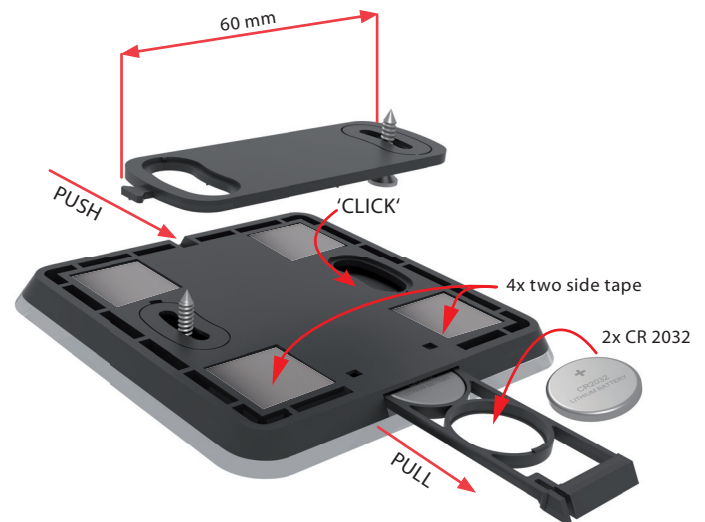

Variants



RFGB-220/W

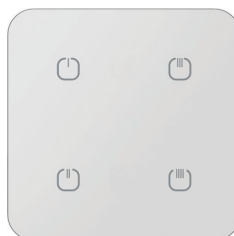

RFGB-240/W



RFGB-220/B



RFGB-240/B

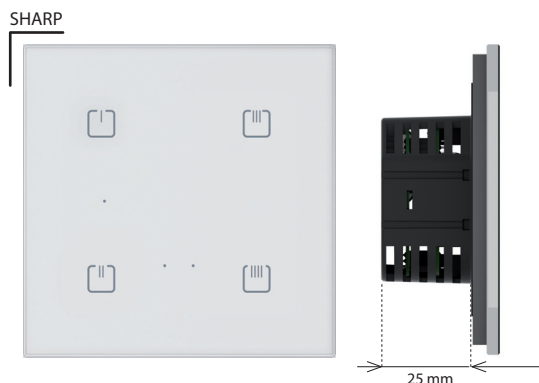

Technical parameters	RFDW-71/230V	RFDW-71/120V
Supply voltage:	230 V AC/50 Hz	120 V AC/60 Hz
Apparent power:	1.1 VA	1.1 VA
Dissipated power:	0.8 W	0.8 W
Supply voltage tolerance:	±10 %	
Dimmed load:	R,L,C, LED, ESL	
Input		
Temperature measuring:	YES, built-in temperature sensor	
Scope and accuracy of temp. measurement:	0 to +55 °C; 0.3 °C from the range	
Output		
Contactless:	2 x MOSFET	
Load capacity:*	max. 160 W	max. 80 W
Control		
Wireless:	up to 25-channels (buttons)	
Communication protocol:	RFIO2	
Frequency:	866–922 MHz (for more information see p. 76)	
Repeater function:	yes	
Manual control:	4 touch keys, button PROG	
Indications touch keys:	red/green LED	
Indications PROG:	colour adjustable prog. mode	
Range:	in open space up to 160 m	
Connection		
Terminals:	0.5–1 mm ²	
Other data		
Operating temperature:	-20 to +35 °C	
Storing temperature:	-30 to +70 °C	
Protection degree:	IP20	
Overvoltage category:	II.	
Pollution degree:	2	
Operation position:	any	
Installation:	into installation box	
Dimensions:	94 x 94 x 36 mm	
Weight:	155 g	

* See page 75 for the load chart for each light source.

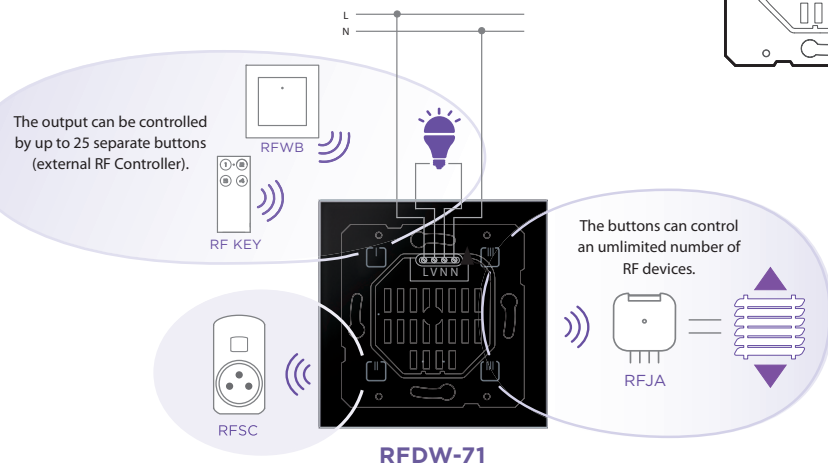

- Glass touch controller with integrated dimming component which serves to regulate light sources:
 - R – classic lamps (resistive load)
 - L – halogen lamps with wound transformer (inductive load)
 - C – halogen lamps with electronic transformer (capacity load)
 - ESL – dimmable energy-efficient fluorescent lamps
 - LED – LED light sources (230 V) equipped with LED.
- 4-channels switch version allows you to control the integrated dimmer as well as other components of the installation.
- They can be combined with detectors, controllers, iNELS RF Control or system components.
- 6 light functions – smooth increase or decrease with time setting 2 s – 30 min. Function description can be found on page 75.
- When switched off, the set level is stored in the memory, and when switched back on, it returns to the most recently set value.
- Thanks to setting the min. brightness by potentiometer, you will eliminate flashing of the LED and ESL light sources.
- The universal dimmer may be controlled by up to 25-channels.
- The programming button on the controller is also used for manual control of the output.
- Memory status can be pre-set in the event of a power failure.
- Range up to 160 m (in open space), if the signal is insufficient between the controller and unit, use the signal repeater RFRP-20 or protocol component RFIO2 that support this feature.
- Communication frequency with bidirectional protocol RFIO2.

Colour variants



RFDW-71/B

RFDW-71/W

Connection

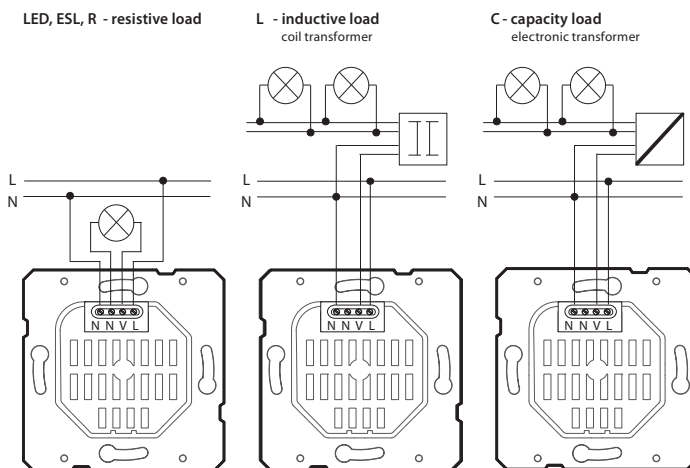

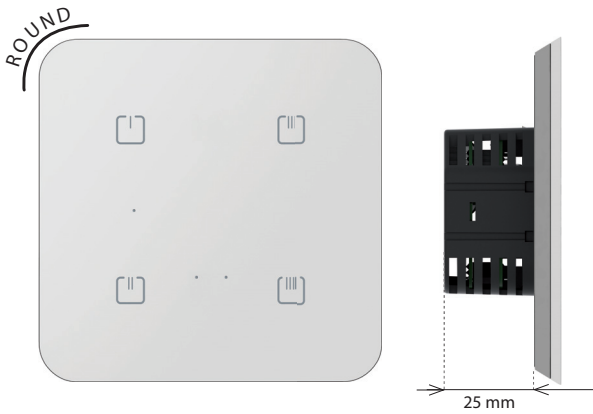

- Glass touch controller with integrated dimming component which serves to regulate light sources:
 - R – classic lamps (resistive load)
 - L – halogen lamps with wound transformer (inductive load)
 - C – halogen lamps with electronic transformer (capacity load)
 - ESL – dimmable energy-efficient fluorescent lamps
 - LED – LED light sources (230 V) equipped with LED.
- 4-channels switch version allows you to control the integrated dimmer as well as other components of the installation.
- They can be combined with detectors, controllers, iNELS RF Control or system components.
- 6 light functions – smooth increase or decrease with time setting 2 s – 30 min. Function description can be found on page 75.
- When switched off, the set level is stored in the memory, and when switched back on, it returns to the most recently set value.
- Thanks to setting the min. brightness by potentiometer, you will eliminate flashing of the LED and ESL light sources.
- The universal dimmer may be controlled by up to 25-channels.
- The programming button on the controller is also used for manual control of the output.
- Memory status can be pre-set in the event of a power failure.
- Range up to 160 m (in open space), if the signal is insufficient between the controller and unit, use the signal repeater RFRP-20 or protocol component RFIO2 that support this feature.
- Communication frequency with bidirectional protocol RFIO2.

Technical parameters	RFDW-271/230V	RFDW-271/120V
Supply voltage:	230 V AC/50 Hz	120 V AC/60 Hz
Apparent power:	1.1 VA	1.1 VA
Dissipated power:	0.8 W	0.8 W
Supply voltage tolerance:	±10 %	
Dimmed load:	R,L,C, LED, ESL	
Input		
Temperature measuring:	YES, built-in temperature sensor	
Scope and accuracy of temp. measurement:	0 to +55 °C; 0.3 °C from the range	
Output		
Contactless:	2 x MOSFET	
Load capacity*:	max. 160 W	max. 80 W
Control		
Wireless:	up to 25-channels (buttons)	
Communication protocol:	RFIO2	
Frequency:	866–922 MHz (for more information see p. 76)	
Repeater function:	yes	
Manual control:	4 touch keys, button PROG	
Indications touch keys:	red/green LED	
Indications PROG:	colour adjustable prog. mode	
Range:	in open space up to 160 m	
Connection		
Terminals:	0.5–1 mm ²	
Other data		
Operating temperature:	-20 to +35 °C	
Storing temperature:	-30 to +70 °C	
Protection degree:	IP20	
Overvoltage category:	II.	
Pollution degree:	2	
Operation position:	any	
Installation:	into installation box	
Dimensions:	100 x 100 x 36 mm	
Weight:	155 g	

Colour variants



RFDW-271/B



RFDW-271/W

Connection

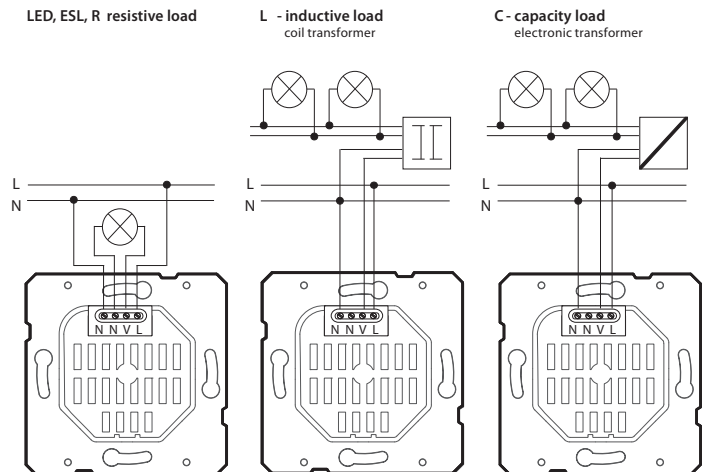

* See page 75 for the load chart for each light source.

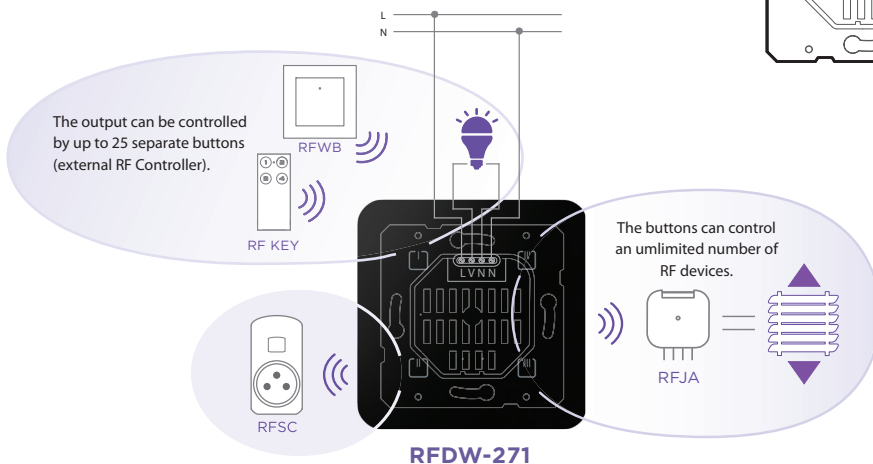



RFDW-271/B | Glass touch controller



Glass touch controller | RFGB-40/W



RFGB-40/W | Glass touch controller



- Key fob – sized remote control, available in black and white.
- When pressing the button, it sends a set signal (ON/OFF, dimming, time switching OFF/ON, blinds up/down).
- **RF KEY-40:** four buttons enable control of four units independently.
- **RF KEY-60:** six buttons enable control of four units independently.
- Battery power supply (3 V CR 2032 battery - included in the supply) with battery life of around 5 years based on frequency of use.

Technical parameters	RF KEY-40	RF KEY-60
Supply voltage:	3 V CR 2032 battery	
Battery life:	around 5 years based on frequency of use	
Transmission indication:	red LED	
Number of buttons:	4	6
Communication protocol:	RFIO2	
Transmitter frequency:	866–922 MHz (for more information see p. 76)	
Signal transmission method:	unidirectionally addressed message	
Range:	in open space up to 200 m	
Other data		
Operating temperature:	-10 to +50 °C	
Operating position:	any	
Colour design:	white, black	
Protection:	IP20	
Contamination degree:	2	
Dimensions:	64 x 25 x 10 mm	
Weight:	16 g	
Related standards:	EN 60669, EN 300 220, EN 301 489 R&TTE Directive, Order. No 426/2000 Coll. (Directive 1999/EC)	

Device description

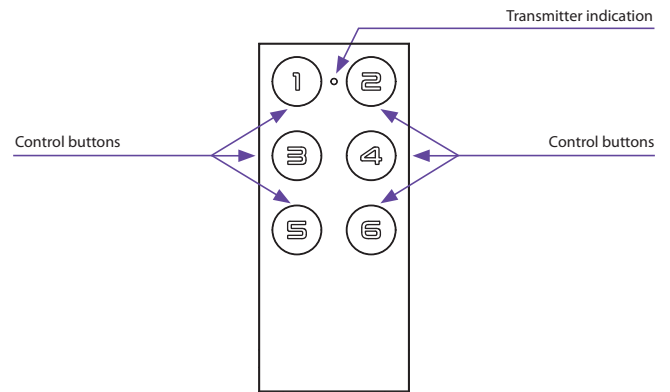

Variants



RF KEY-40/W



RF KEY-60/W



RF KEY-40/B



RF KEY-60/B



Technical parameters	RF Pilot/W	RF Pilot/A
Display		
Type:	colour OLED	
Resolution:	128 x 128 pixels	
Side ratio:	1:1	
Visible surface:	26 x 26 mm	
Backlighting:	self-illuminating text	
Diagonal:	1.5"	
Control:	direction button, control buttons	
Power supply		
Power supply:	2 x 1.5 V AAA batteries/R03	
Battery life:	approx. 3 years, according to the frequency of use and battery type	
Control		
Range:	in open space up to 200 m	
Communication protocol:	RFIO	
Frequency:	866–922 MHz (for more information see p. 76)	
Other data		
Operating temperature:	0 to +55 °C	
Storage temperature:	-20 to +70 °C	
Colour design:	white	anthracite
Protection:	IP20	
Operating position:	any	
Dimensions:	130 x 41 x 18 mm	
Weight:	61 g	
Related standards:	EN 60730-1	

RF Pilot



- The Remote RF controller with display is a central controller for switching electrical appliances and equipment, dimming lights, controlling blinds, etc.
- Designed in white and anthracite with colour OLED display.
- 4 directional joystick + 2 buttons for intuitive operation.
- Option of setting light scenes, where with a single press, you can control up to 40 units at once.
- Display of room temperature, battery status, date and time directly on display.
- The Favorites mode lets you preset the most frequently used devices on the home screen.
- Bidirectional communication, transmits and receives commands and displays the status of units.
- Thanks to the function of measuring the signal between the controller and unit, you can use it for testing the range and signal quality.
- Battery power (2x 1.5 V AAA batteries - included in supply) with battery life of around 3 years based on frequency of use and type of batteries.
- Range up to 200 m (in open space), if the signal is insufficient between the controller and unit, use the signal repeater RFRP-20 or protocol component RFIO2 that support this feature.
- Communication frequency with bidirectional protocol RFIO.

Device description

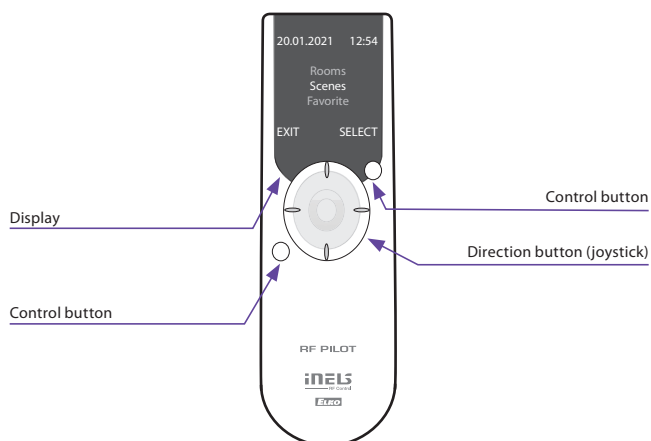

Display description

Colour LED display

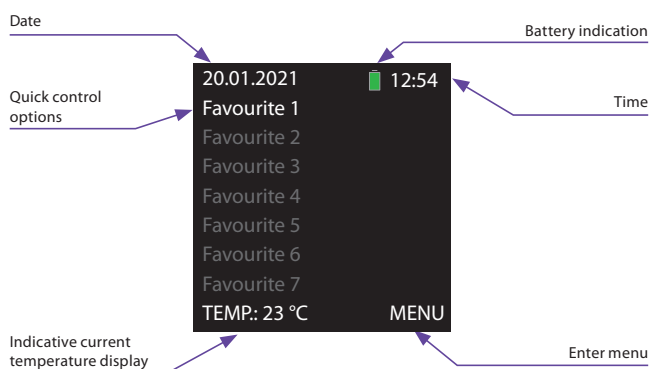

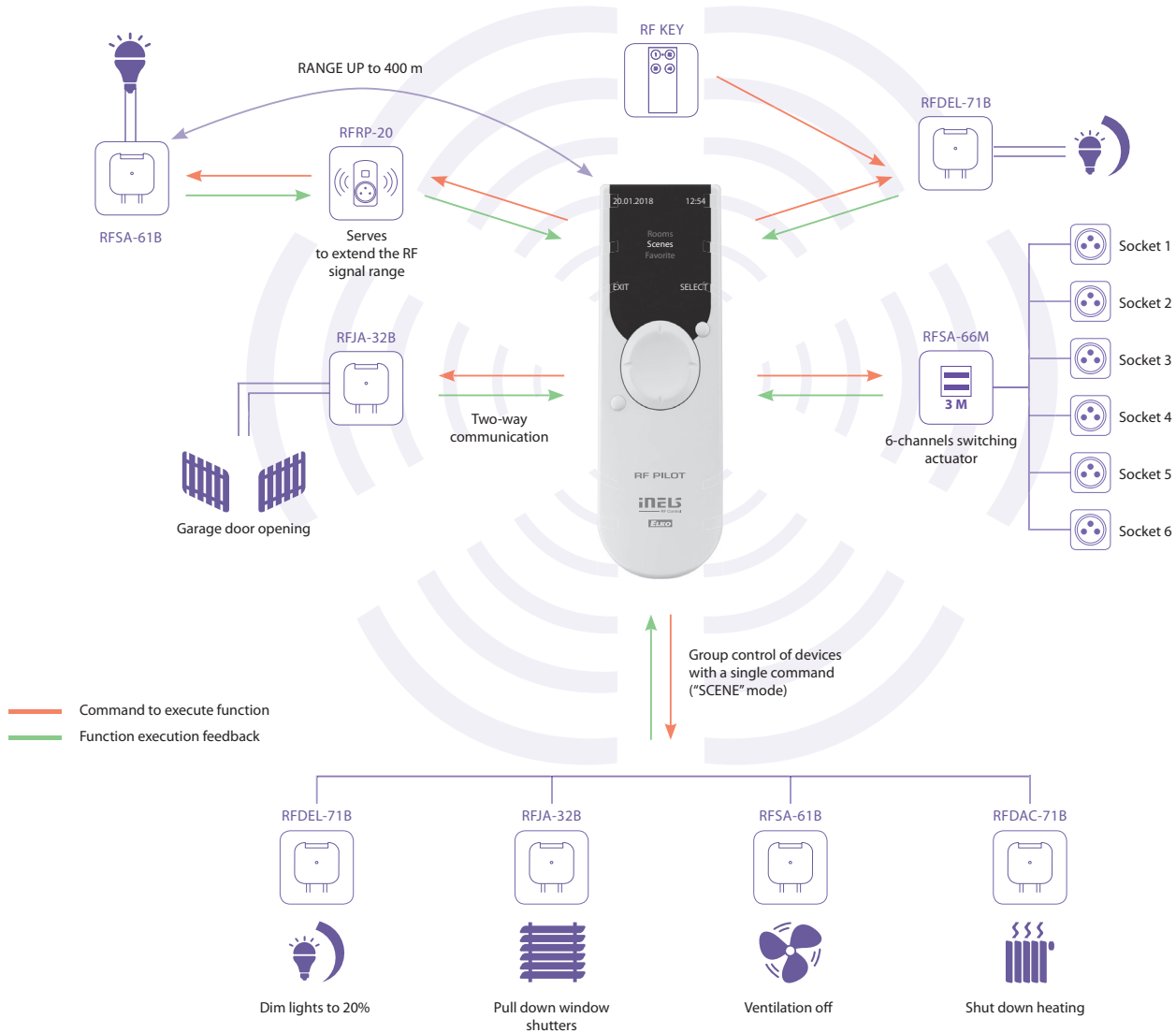

SCENES

- serves to control actuators as a group with a single touch
- possibility to set up scenes; on activation, for example, window shutters are pulled down and the light will adjust to the required brightness

WINDOW SHUTTERS

- controlling window shutters, blinds, garage door, etc.
- window shutters are controlled separately or as a group
- the window shutter receivers are powered by either 230 V or 24 V DC (shutters between windows)

FAVOURITE

- serves to select the most frequently used devices
- on display activation, the "Favourite" menu pops up automatically to provide you with a quick access to controlling devices

SWITCHING

- this function serves to switch on/off lights, sockets, electrical appliances and devices
- intuitive control thanks to customized name options
- switching actuator function selections: switch on/off, impulse relay, button, delayed ON/OFF (time of delay from 2 seconds to 60 minutes)

DIMMING

- the regulation of light intensity (light bulbs, LED strips, halogen lights with electrical or coil transformer, fluorescent tubes with dimmable ballast 1–10 V)
- customizable names of individual dimmed circuits (such as "lights" or "living room")
- "sunrise/sunset" imitation - light gradually goes on or off during the preset period between 2 seconds and 30 minutes

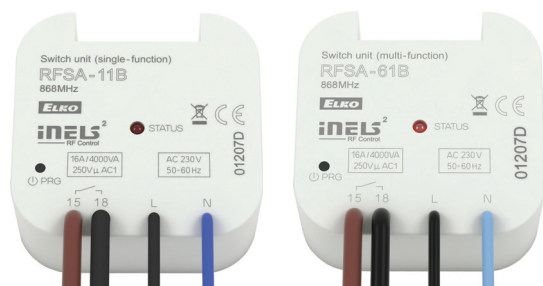

Technical parameters	RFSA-11B/230V RFSA-61B/230V	RFSA-11B/120V RFSA-61B/120V	RFSA-11B/24V RFSA-61B/24V
Supply voltage:	230 V AC	120 V AC	12–24 V AC/DC
Supply voltage frequency:	50–60 Hz	60 Hz	50–60 Hz
Apparent input:	7 VA/cos φ=0.1	7 VA/cos φ=0.1	-
Dissipated power:	0.7 W	0.7 W	0.7 W
Supply voltage tolerance:	+10 %; -15 %		

Output

Number of contacts:	1x switching (AgSnO ₂)
Rated current:	16 A/AC1
Switching power:	4000 VA/AC1, 384 W/DC
Peak current:	30 A/<3 s
Switching voltage:	250 V AC1/24 V DC
Max. DC switching power:	500 mW
Mechanical service life:	3x 10 ⁷
Electrical service life (AC1):	0.7x 10 ⁵

Control

Wireless:	up to 25-channels (buttons)
Communication protocol:	RFIO2
Frequency:	866–922 MHz (for more information see p. 76)
Repeater function:	yes
Manual control:	button PROG (ON/OFF)
Range:	in open space up to 200 m

Other data

Operating temperature:	-15 to +50 °C
Operating position:	any
Mounting:	free at lead-in wires
Protection:	IP30
Overvoltage category:	III.
Contamination degree:	2
Terminals (CY wire, cross-section):	2x 0.75 mm ² , 2x 2.5 mm ²
Length of terminals:	90 mm
Dimensions:	49 x 49 x 21 mm
Weight:	46 g
Related standards:	EN 60669, EN 300 220, EN 301 489 R&TTE Directive, Order. No 426/2000 Coll. (Directive 1999/EC)

- The switching unit with 1 output channel 16 A is used to control appliances, lights (easy to integrate it to control garage doors or gates).
- They can be combined with detectors, controllers, iNELS RF Control or system components.
- **RFSA-11B:** singlefunction design – switch on/off.
- **RFSA-61B:** multifunction design – button, impulse relay and time function of delayed ON or OFF with time setting of 2 s – 60 min. Function description can be found on page 74.
- The switching unit may be controlled by up to 25-channels.
- The programming button on the unit is also used for manual control of the output.
- Memory status can be pre-set in the event of a power failure.
- Range up to 200 m (in open space), if the signal is insufficient between the controller and unit, use the signal repeater RFRP-20 or protocol component RFIO2 that support this feature.
- Communication frequency with bidirectional protocol RFIO2.
- The BOX design lets you mount it right in an installation box, a ceiling or controlled appliance cover.

Device description

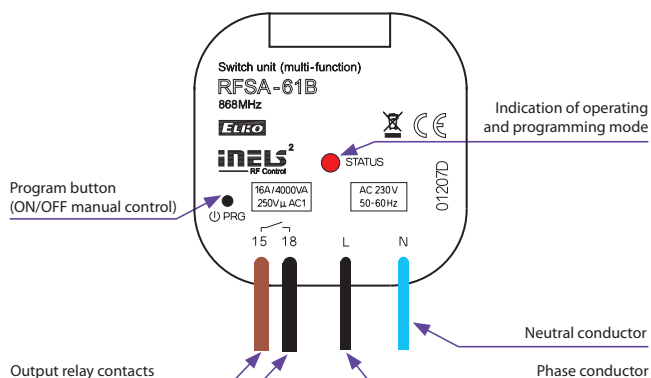

Connection

RFSA-11B/230V, RFSA-61B/230V
RFSA-11B/120V, RFSA-61B/120V

RFSA-61B/24V

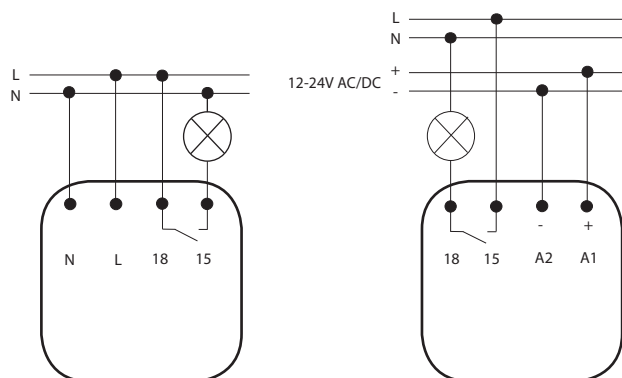

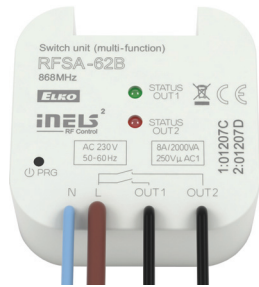

Technical parameters	RFSA-62B/230V	RFSA-62B/120V	RFSA-62B/24V
Supply voltage:	230 V AC	120 V AC	12–24 V AC/DC
Supply voltage frequency:	50–60 Hz	60 Hz	50–60 Hz
Apparent input:	7 VA/cos φ=0.1	7 VA/cos φ=0.1	-
Dissipated power:	0.7 W	0.7 W	0.7 W
Supply voltage tolerance:	+10 %; -15 %		
Output			
Number of contacts:	2 x switching (AgSnO ₂)		
Rated current:	8 A/AC1		
Switching power:	2000 VA/AC1		
Peak current:	10 A/<3 s		
Switching voltage:	250 V AC1		
Max. DC switching power:	500 mW		
Mechanical service life:	1x10 ⁷		
Electrical service life (AC1):	1x10 ⁵		
Control			
Wireless:	each of the outputs up to 12-channels (buttons)		
Communication protocol:	RFIO2		
Frequency:	866–922 MHz (for more information see p. 76)		
Repeater function:	yes		
Manual control:	button PROG (ON/OFF)		
Range:	in open space up to 100 m		
Other data			
Operating temperature:	-15 to +50 °C		
Operating position:	any		
Mounting:	free at lead-in wires		
Protection:	IP30		
Overvoltage category:	III.		
Contamination degree:	2		
Terminals (CY wire, cross-section):	1x 2.5 mm ² , 3x 0.75 mm ²	1x2.5, 4x0.75 mm ²	
Length of terminals:	90 mm		
Dimensions:	49 x 49 x 21 mm		
Weight:	46 g		
Related standards:	EN 60669, EN 300 220, EN 301 489 R&TTE Directive, Order. No 426/2000 Coll. (Directive 1999/EC)		

- The switching unit with 2 output channels 8 A used to control two independent appliances.
- They can be combined with detectors, controllers, iNELS RF Control or system components.
- Function: button, impulse relay and time function of delayed start and return with time setting range of 2 s – 60 min. Function description can be found on page 74.
- Each of the channels may be controlled by up to 12-channels.
- The programming button on the unit is also used for manual control of the output.
- Memory status can be pre-set in the event of a power failure.
- Range up to 100 m (in open space), if the signal is insufficient between the controller and unit, use the signal repeater RFRP-20 or protocol component RFIO2 that support this feature.
- Communication frequency with bidirectional protocol RFIO2.
- The BOX design lets you mount it right in an installation box, a ceiling or controlled appliance cover.

Device description

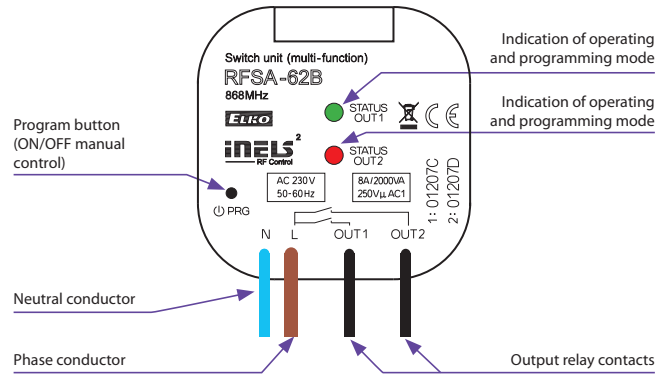

Connection

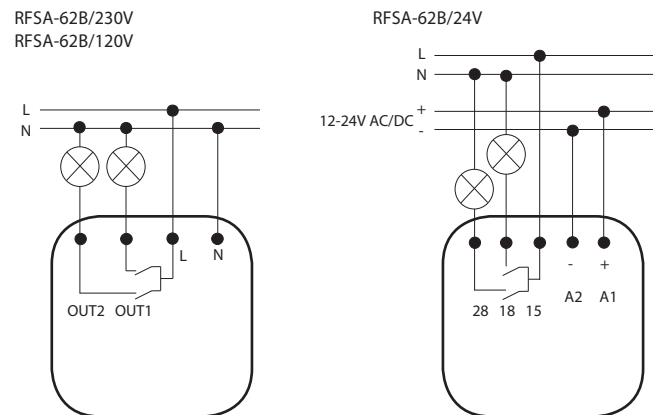

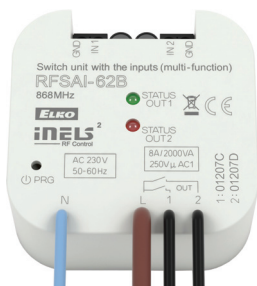

Technical parameters	RFSAI-62B/230V	RFSAI-62B/120V
Supply voltage:	230 V AC	120 V AC
Supply voltage frequency:	50–60 Hz	60 Hz
Apparent power:	7 VA/cos φ= 0.1	
Dissipated power:	0.7 W	
Supply voltage tolerance:	+10 %; -15 %	

Output

Number of contacts:	2x switching (AgSnO ₂)
Rated current:	8 A/AC1
Switching power:	2000 VA/AC1, 192 W/DC
Peak current:	10 A/<3 s
Switching voltage:	250 V AC1/24 V DC
Min. switching power DC:	500 mW
Mechanical service life:	1x10 ⁷
Electrical service life (AC1):	1x10 ⁵

Controlling

Wireless:	each of the outputs up to 12-channels (buttons)
Communication protocol:	RFIO2
Frequency:	866–922 MHz (for more information see p. 76)
Repeater function:	yes
Manual control:	button PROG (ON/OFF)
External button:	max. 12 m wire ⚠*
Range:	in open space up to 200 m

Other data

Voltage of open contact:	2.5 V
Resist. of connection for closed contact:	<1 kΩ
Resist. of connection for open contact:	>10 kΩ
Galvanic isolation of input:	no ⚠
Operating temperature:	-15 to +50 °C
Working position:	any
Mounting:	free at lead-in wires
Protection:	IP30
Overvoltage category:	III.
Contamination degree:	2
Terminals (CY wire, Cross-section):	3x 0.75, 1x 2.5 mm ²
Terminal length:	90 mm
Dimensions:	49 x 49 x 21 mm
Weight:	46 g
Related standards:	EN 60669, EN 300220, EN 301489 R&TTE Directive, Order. No 426/2000 Coll. (Directive 1999/EC)

* We recommend using a twisted pair cable for this distance.

⚠ The external button inputs are at the potential of the main supply voltage.

- The switch with 2 output 8 A contacts is used to control 2 independent appliances. Is equipped with inputs for connecting to external buttons for local control.
- They can be combined with detectors, controllers, iNELS RF Control or system components.
- Function: button, impulse relay and time function of delayed start or return with time setting range of 2 s – 60 min. It is possible to assign any function to each output relay. Function description can be found on page 74.
- External button is programmed as a wireless button.
- Input is not galvanic isolated!
- Each output can be controlled by up to 12-channels.
- Memory status can be pre-set in the event of a power failure.
- Range up to 200 m (in open space), if the signal is insufficient between the controller and unit, use the signal repeater RFRP-20 or protocol component RFIO2 that support this feature.
- Communication frequency with bidirectional protocol RFIO2.
- The BOX design lets you mount it right in an installation box, a ceiling or controlled appliance cover.

Device description

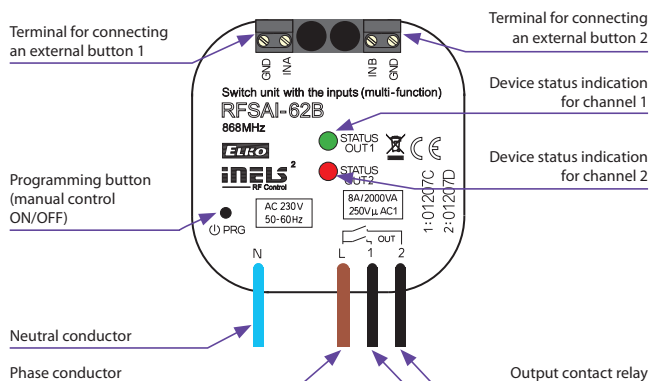

Connection

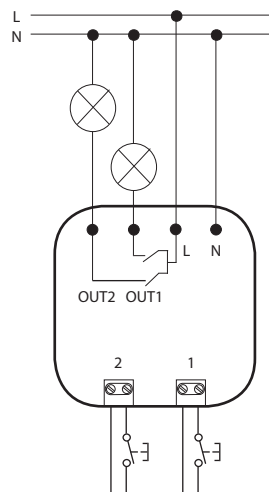

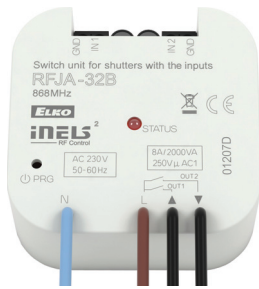

Technical parameters	RFJA-32B/230V	RFJA-32B/120V	RFJA-32B/24V
Supply voltage:	230 V AC	120 V AC	5–24 V DC
Supply voltage frequency:	50–60 Hz	60 Hz	x
Apparent input:	7 VA/cos φ= 0.1	7 VA/cos φ= 0.1	x
Dissipated power:	0.7 W	0.7 W	x
Power without load:		x	0.5 W
Power under load:		x	20 W
Supply voltage tolerance:		+10 %; -15 %	

Input	
Input:	2x switch or GND

Output		
Number of contacts:	2 x switching (AgSnO ₂)	contactless
Rated current:	8 A/AC1	1 A
Switching power:	2000 VA/AC1	x
Peak current:	10 A/<3 s	1.5 A/<3 s
Switching voltage:	250 V AC1	5–24 V DC*
Mechanical service life:	1x10 ⁷	x
Electrical service life (AC1):	1x10 ⁵	x

Control	
Wireless:	up to 25-channels (buttons)
Communication protocol:	RFIO2
Frequency:	866–922 MHz (for more information see p. 76)
Repeater function:	yes
Manual control:	PROG (STOP, ▲, STOP, ▼)
External button:	max. 12 m wire ▲**
Range:	in open space up to 100 m

Other data		
Operating temperature:	-15 to +50 °C	
Operating position:	any	
Mounting:	free at lead-in wires	
Protection:	IP30	
Overvoltage category:	III.	
Contamination degree:	2	
Terminals:	0.5–1 mm ²	
Terminals (CY wire, cross section):	4 x 0.75 mm ²	
Length of terminals:	90 mm	
Dimensions:	49 x 49 x 21 mm	49 x 49 x 13 mm
Weight:	46 g	22 g
Related standards:	EN 60669, EN 300 220, EN 301 489 R&TTE Directive, Order. No 426/2000 Coll. (Directive 1999/EC)	

* Identical with supply voltage.

** We recommend using a twisted pair cable for this distance.

▲ The external button inputs are at the potential of the main supply voltage.

- The switching unit for blinds has 2 output channels used to control garage doors, gates, blinds, awnings, etc.
- It can be combined with Control or System units iNELS RF Control.
- **RFJA-32B/230V (120V):** relay contacts 2x 8 A (2x 2000 W), with the possibility of connecting external buttons. The relays block each other (only one direction of movement at a time).
- **RFJA-32B/24VDC:** contactless quiet switching with the ability to connect existing buttons. The drive is controlled by changing the polarity.
- Short presses (<2 s) of the controller enable tilting of lamellas, and a long press (>2 s) enables you to draw the blinds up or down to the end position.
- Each of the units may be controlled by up to 25-channels.
- The programming button on the unit is also used for manual control of the output.
- Range up to 100 m (in open space), if the signal is insufficient between the controller and unit, use the signal repeater RFRP-20 or protocol component RFIO2 that support this feature.
- Communication frequency with bidirectional protocol RFIO2.
- The BOX design lets you mount it right in an installation box, a ceiling or motor drive cover.

Device description

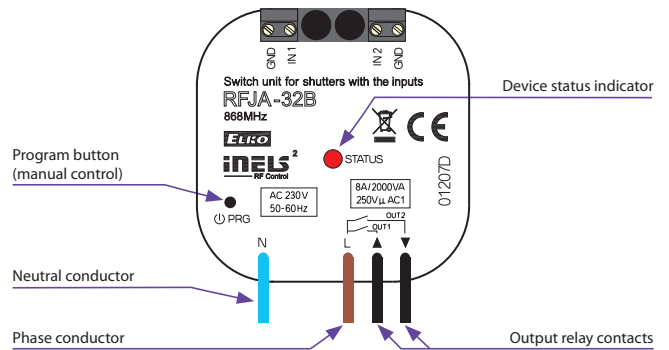

Function description

1. Short presses (<2 s) of the control allow the slats to be tilted.
2. When the control button is pressed >2 s shutters move up (▲) or down (▼) until reaching the final position. The travel time of the blinds is set with the programming button.

Connection

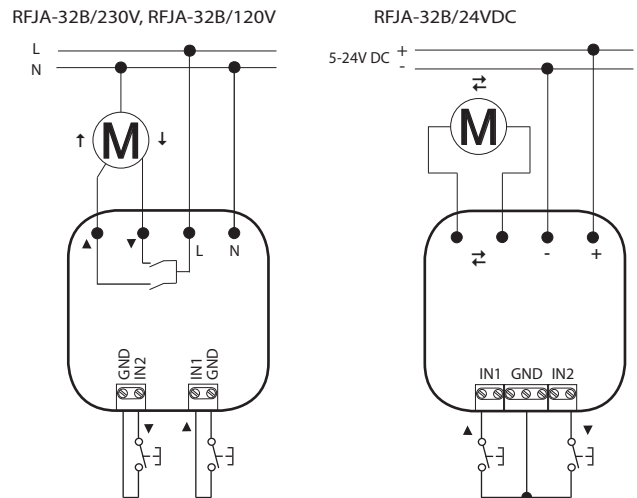



- **RFSA-61M:** the switching unit with 1 output channel 16 A is used for controlling appliances, sockets or lights.
 - the 1-MODULE design of the unit into a switchboard.
 - the switching unit may be controlled by up to 25-channels.
 - the package includes an internal antenna AN-I, in case of locating the element in a metal switchboard, you can use the external antenna AN-E for better signal reception, see accessories on page 75.
- **RFSA-61MI:** same design and function as RFSA-61M, but with integrated antenna. It is suitable for placement in cabinets with plastic doors.
- 6 function: button, impulse relay and time function of delayed start or return with time setting range of 2 s – 60 min. Function description can be found on page 74.
- The programming button on the unit is also used for manual control of the output.
- Memory status can be pre-set in the event of a power failure.

Technical parameters	RFSA-61MI/230V	RFSA-61M/230V
Supply voltage:	110–230 V AC	
Supply voltage frequency:	50–60 Hz	
Apparent input:	2.7 VA $\cos \varphi = 0.6$	
Dissipated power:	1.62 W	
Supply voltage tolerance:	+10%/–25 %	
Output		
Number of contacts:	1x changeover	
Rated current:	16 A/AC1	
Switching power:	4000 VA/AC1, 384 W/DC	
Peak current:	30 A/<3 s	
Switching voltage:	250 V AC1/24 V DC	
Contact material:	AgSnO ₂	
Mechanical service life:	3x10 ⁷	
Electrical service life (AC1):	0.7x10 ⁵	
Control		
Wireless:	up to 25-channels (buttons)	
Communication protocol:	RFIO2	
Frequency:	866–922 MHz (for more information see p. 76)	
Repeater function:	yes	
Manual control:	PROG (ON/OFF) button	
Range:	in open space up to 200 m	
RF Antenna:	integrated	external *
Other data		
Operating temperature:	–15 °C to +50 °C	
Operating position:	any	
Mounting:	DIN rail EN 60715	
Protection:	IP20 from the front panel	
Overvoltage category:	III.	
Contamination degree:	2	
Connecting conductor cross-section (mm ²):	max. 1x 2.5, max. 2x 1.5/ with a hollow max. 1x 2.5	
Dimensions:	90 x 17.6 x 64 mm	
Weight:	69 g	75 g
Related standards:	EN 60669, EN 300 220, EN 301 489 R&TTE Directive, Order. No 426/2000 Coll. (Directive 1999/EC)	

* AN-I antenna (with SMA connector) is part of packaging.
Other antennas with cable are available on the page 69.
Max tightening torque for antenna's connector is 0.56 Nm.

Device description

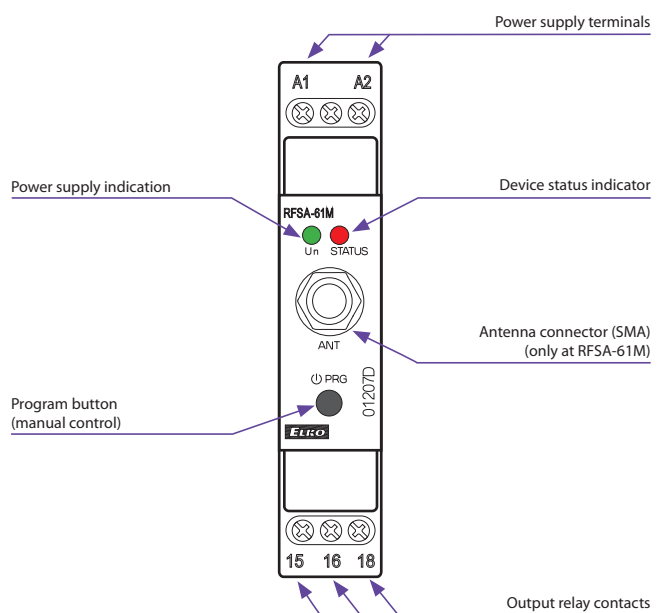

Connection





- **RFS-66M:** the switching unit with 6 output channels 8 A is used for independent control of up to 6 appliances, sockets or lights.
 - the 3-MODULE design of the unit into a switchboard.
 - each of the channels may be controlled by up to 25-channels.
 - the package includes an internal antenna AN-I, in case of locating the element in a metal switchboard, you can use the external antenna AN-E for better signal reception, see accessories on page 75.
- **RFS-66MI:** same design and function as RFS-61M, but with integrated antenna. It is suitable for placement in cabinets with plastic doors.
- **6 function:** button, impulse relay and time function of delayed start or return with time setting range of 2 s – 60 min. Function description can be found on page 74.
- The programming button on the unit is also used for manual control of the output.
- Memory status can be pre-set in the event of a power failure.

Technical parameters	RFS-66MI/230V	RFS-66MI/24V	RFS-66M/230V	RFS-66M/24V
Supply voltage:	110–230 V AC	12–24 V AC/DC	110–230 V AC	12–24 V AC/DC
SELV:	no	yes	no	yes
Supply voltage frequency:	AC 50–60 Hz			
Apparent input:	min. 2 VA/ max. 5 VA	-	min. 2 VA/ max. 5 VA	-
Dissipated power:	min. 0.5W/ max. 2.5W	max. 1.8 W	min. 0.5W/ max. 2.5W	max. 1.8 W
Supply voltage tolerance:	+10%/-25 %			
Output				
Number of contacts:	3x changeover, 3x switching			
Rated current:	8 A/AC1			
Switching power:	2000 VA/AC1			
Peak current:	10 A/<3 s			
Switching voltage:	250 V AC1			
Contact material:	AgSnO ₂			
Mechanical service life:	1x10 ⁷			
Electrical service life (AC1):	1x10 ⁵			
Control				
Wireless:	up to 25-channels (buttons)			
Communication protocol:	RFIO2			
Frequency:	866–922 MHz (for more information see p. 76)			
Repeater function:	yes			
Manual control:	PROG (ON/OFF) button			
Range:	in open space up to 200 m			
RF Antenna:	integrated	external *	integrated	external *
Other data				
Operating temperature:	-15 °C to +50 °C			
Operating position:	any			
Mounting:	DIN rail EN 60715			
Protection:	IP20 from the front panel			
Overvoltage category:	III.			
Contamination degree:	2			
Connecting conductor cross-section (mm ²):	max. 1x 2.5, max. 2x 1.5/ with a hollow max. 1x 2.5			
Dimensions:	90 x 52 x 65 mm			
Weight:	171 g		179 g	
Related standards:	EN 60669, EN 300 220, EN 301 489 R&TTE Directive, Order. No 426/2000 Coll. (Directive 1999/EC)			

Device description

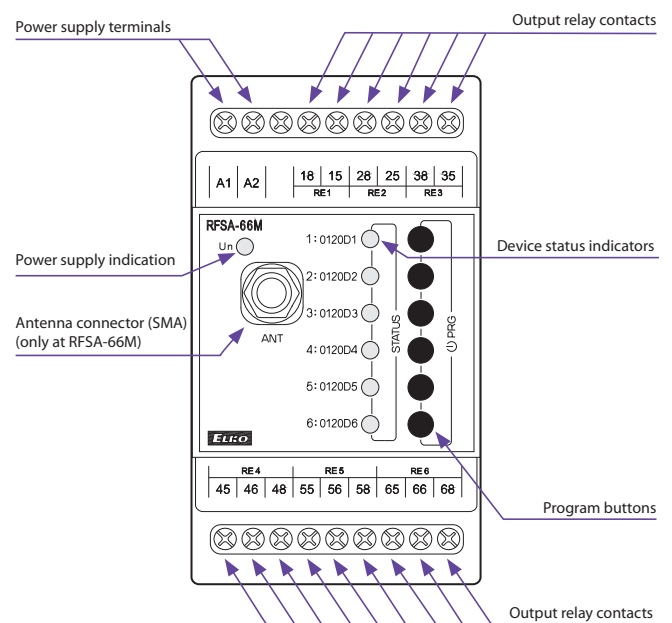

Connection

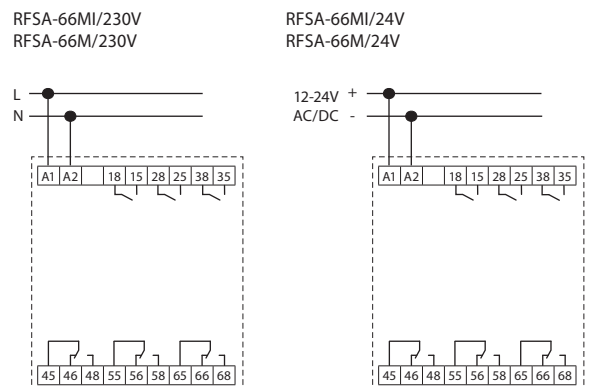

* AN-I antenna (with SMA connector) is part of packaging. Other antennas with cable are available on the page 69. Max tightening torque for antenna's connector is 0.56 Nm.



Technical parameters	RFUS-61/230V	RFUS-61/120V
Supply voltage:	230 V AC	120 V AC
Supply voltage frequency:	50–60 Hz	60 Hz
Apparent power:	5 VA/cos φ= 0.1	5 VA/cos φ= 0.1
Dissipated power:	0.6 W	0.6 W
Supply voltage tolerance:	+10 %; -15 %	

Output

Rated current:	1x switching (AgSnO ₂)
Number of contacts:	12 A/AC1
Switching power:	3000 VA/AC1, 384 W/DC
Peak current:	30 A/<3 s
Switching voltage:	250 V AC1/24 V DC
Min. switching power DC:	500 mW
Mechanical service life:	3x10 ⁷
Electrical service life (AC1):	0.7x10 ⁵

Control

Wireless:	up to 25-channels (buttons)
Communication protocol:	RFIO2
Frequency:	866–922 MHz (for more information see p. 76)
Repeater function:	yes
Manual control:	PROG (ON/OFF) button
Range:	in open space up to 200 m

Other data

Operating temperature:	-15 to +50 °C
Operating position:	any
Mounting:	screws
Protection:	IP65
Overvoltage category:	III.
Contamination degree:	2
Cross-section of connecting wires (mm ²):	max. 1x 2.5, max. 2x 1.5/ with a hollow max. 1x 2.5
Recommended power cord:	CYKY 3x1.5 (CYKY 4x1.5)
Dimensions:	136 x 62 x 34 mm
Weight:	146 g
Related standards:	EN 60669, EN 300 220, EN 301 489 R&TTE Directive, Order. No 426/2000 Coll. (Directive 1999/EC)

- The switching unit with 1x 12 A output channel is used for controlling appliances, sockets or lights.
- They can be combined with detectors, controllers, iNELS RF Control or system components.
- Multi-function design – button, impulse relay and time function of delayed ON or OFF with time setting of 2 s – 60 min. Function description can be found on page 74.
- The switching unit may be controlled by up to 25-channels.
- The programming button on the unit is also used for manual control of the output.
- Range up to 200 m (in open space), if the signal is insufficient between the controller and unit, use the signal repeater RFRP20 or protocol component RFIO2 that support this feature.
- Communication frequency with bidirectional protocol RFIO2.
- The increased IP 65 protection is suited to mounting on the wall or in harsh environments such as the cellar, garage or bathrooms.

Device description

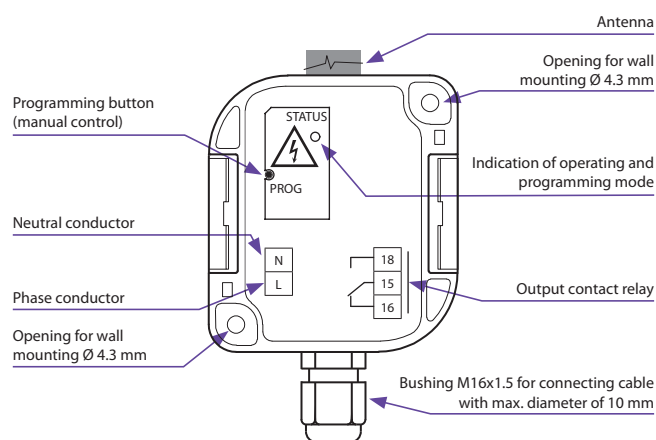

Connection

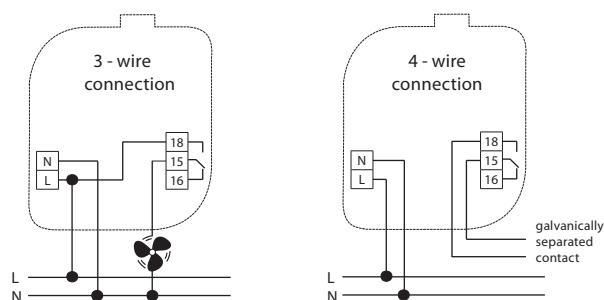



- The switched socket with 16 A output channel is used to control fans, lamps, heaters and appliances, which are connected by a 16 A power cord.
 - They can be combined with detectors, controllers, iNELS RF Control or system components.
 - Multi-function design – button, impulse relay and time function of delayed ON or OFF with time setting of 2 s – 60 min. Function description can be found on page 74.
 - The switched socket may be controlled by up to 32-channels .
 - Thanks to the socket design, installation is simple by direct insertion into the existing socket.
 - The programming button on the socket is also used for manual control of the output.
 - Memory status can be pre-set in the event of a power failure.
 - Range up to 200 m (in open space), if the signal is insufficient between the controller and unit, use the signal repeater RFRP-20 or protocol component RFIO2 that support this feature.
 - Communication frequency with bidirectional protocol RFIO.
- Produced in 3 designs of sockets/plugs:



Device description

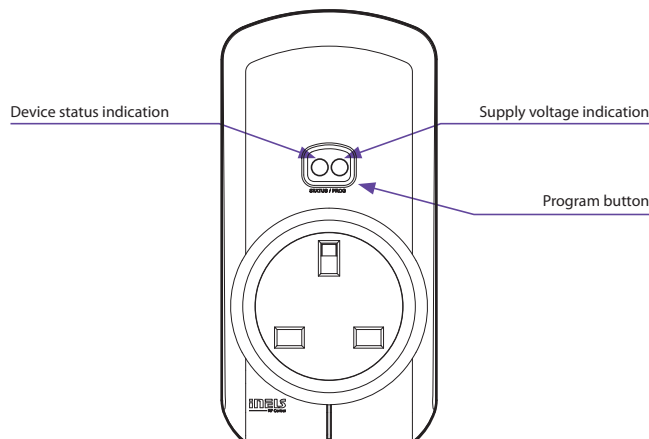

Technical parameters	RFSC-61/230V	RFSC-61/120V
Supply voltage:	230–250 V AC	120 V AC
Supply voltage frequency:	50–60 Hz	60 Hz
Apparent power:	6 VA	
Dissipated power:	0.7 W	
Supply voltage tolerance:	+10 %; -15 %	
Output		
Number of contacts:	1x switching (AgSnO ₂)	
Rated current:	16 A/AC1	
Switching power:	4000 VA/AC1, 384 W/DC	
Peak current:	30 A/<3 s	
Switching voltage:	250 V AC1/24 V DC	
Min. switching power DC:	500 mW	
Mechanical service life:	3x10 ⁷	
Electrical service life (AC1):	0.7x10 ⁵	
Control		
Wireless:	up to 32-channels (buttons)	
Communication protocol:	RFIO	
Frequency:	866–922 MHz (for more information see p. 76)	
Repeater function:	no	
Manual control:	button PROG (ON/OFF)	
Range:	in open space up to 200 m	
Other data		
Operating temperature:	-15 to +50 °C	
Working position:	any	
Mounting:	plug into a socket	
Protection:	IP30	
Overvoltage category:	III.	
Contamination degree:	2	
Dimensions:	60 x 120 x 80 mm	
Weight:	195 g	
Related standards:	EN 60669, EN 300 220, EN 301 489 R&TTE Directive, Order. No 426/2000 Coll. (Directive 1999/EC)	



Technical parameters	RFOSC-61
Supply voltage:	230–250 VAC
Supply voltage frequency:	50–60 Hz
Apparent power:	6 VA
Dissipated power:	0.7 W
Supply voltage tolerance:	+10 %; -15 %
Output	
Number of contacts:	1x switching
Rated current:	10 A
Switching power:	2500 VA/300 W
Switching voltage:	250 V AC1/30 V DC
Contact material:	AgSnO ₂
Mechanical service life:	1x 10 ⁷
Electrical service life (AC1):	1x 10 ⁵
Control	
Wireless:	up to 25-channels (buttons)
Communication protocol:	RFIO2
Frequency:	866–922 MHz (for more information see p. 76)
Repeater function:	no
Manual control:	button PROG (ON/OFF)
Range:	in open space up to 200 m
Other data	
Operating temperature:	-15 to +50 °C
Mounting:	screws
Colour design:	white (RAL 9003)
Cross-section of connecting wires (mm ²):	max. 1x 2.5, max. 2x 1.5/ with a hollow max. 1x 2.5
Recommended power cord:	CYKY 3x 1.5 mm ²
Protection:	IP65
Overvoltage category:	III.
Contamination degree:	2
Dimensions:	64 x 74 x 53 mm
Weight:	185 g
Related standards:	EN 60669, EN 300 220, EN 301 489 R&TTE Directive, Order. No 426/2000 Coll. (Directive 1999/EC)

- Switching socket in IP65 design is intended for installation in the outdoor environment.
- They can be combined with detectors, controllers, iNELS RF Control or system components.
- The switched socket may be controlled by up to 25-channels.
- 6 function: button, impulse relay and time function of delayed start or return with time setting range of 2 s – 60 min. Function description can be found on page 74.
- The programming button on the socket is also used for manual control of the output.
- Memory status can be pre-set in the event of a power failure.

Produced in 2 designs:

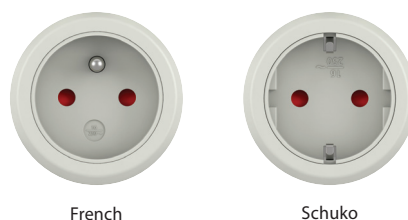

French

Schuko

Device description

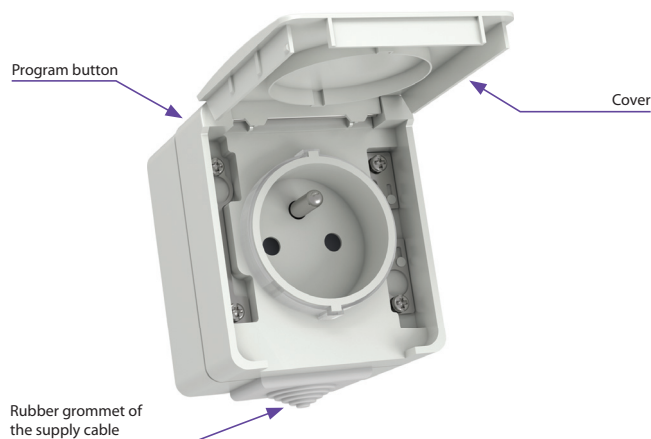

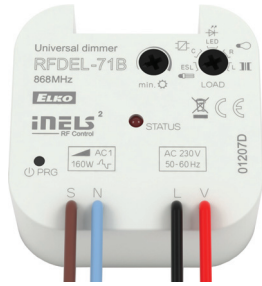

Technical parameters	RFDEL-71B/230V	RFDEL-71B/120V
Supply voltage:	230 V AC	120 V AC
Supply voltage frequency:	50 Hz	60 Hz
Apparent power:	1.1 VA	
Dissipated power:	0.8 W	
Supply voltage tolerance:	+10/-15 %	
Connection:	4-wire, with "NEUTRAL"	
Output		
Dimmed load:	R,L,C, LED, ESL	
Contactless:	2 x MOSFET	
Load capacity*:	max. 160 W	max. 80 W
Control		
Wireless:	up to 25-channels (buttons)	
Communication protocol:	RFIO2	
Frequency:	866-922 MHz (for more information see p. 76)	
Repeater function:	yes	
Range:	in open space up to 160 m	
Manual control:	button PROG (ON/OFF), external button	
Glow lamp connection:	no	
Other data		
Operating temperature:	-20 to +35 °C	
Storage temperature:	-30 to +70 °C	
Operating position:	any	
Mounting:	free at lead-in wires	
Protection:	IP30 under normal conditions	
Overvoltage category:	III.	
Contamination degree:	2	
Terminals (CY wire, Cross-section):	4 x 0.75 mm ²	
Terminal length:	90 mm	
Dimensions:	49 x 49 x 21 mm	
Weight:	40 g	
Related standards:	EN 607 30-1 ED.2	

* See page 75 for the load chart for each light source.

- The universal built-in dimmer is used to regulate light sources:
 - R – classic lamps (resistive load)
 - L – halogen lamps with wound transformer (inductive load)
 - C – halogen lamps with electronic transformer (capacity load)
 - ESL – dimmable energy-efficient fluorescent lamps
 - LED – LED light sources equipped with LED.
- They can be combined with detectors, controllers, iNELS RF Control or system components.
- 6 light functions - smooth increase or decrease with time setting 2 s – 30 min. Function description can be found on page 75.
- Thanks to setting the min. brightness by potentiometer, you will eliminate flashing of the LED and ESL light sources.
- The universal dimmer may be controlled by up to 25-channels.
- Connection of the existing button on the control input „S“ enables combination of wireless control with classic (wired) control.
- The programming button on the controller is also used for manual control of the output.
- Memory status can be pre-set in the event of a power failure.
- Range up to 160 m (in open space), if the signal is insufficient between the controller and unit, use the signal repeater RFRP-20 or protocol component RFIO2 that support this feature.
- Communication frequency with bidirectional protocol RFIO2.
- The BOX design lets you mount it right in an installation box, a ceiling or light cover.

Device description

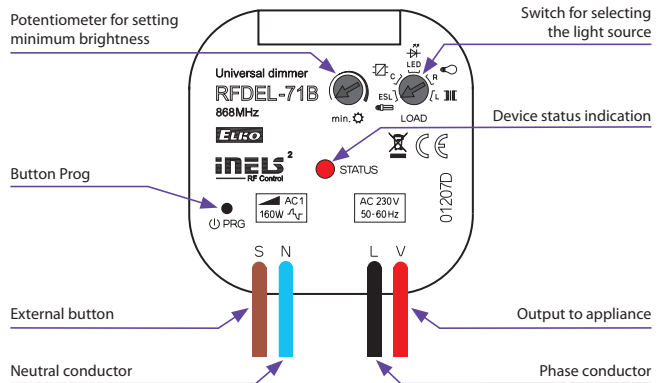

Connection

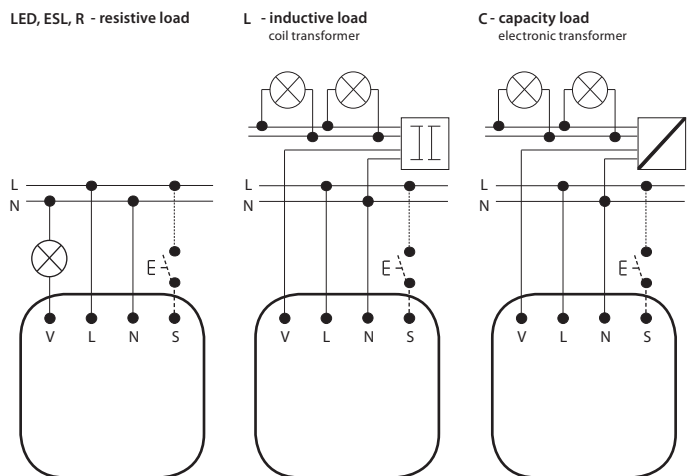

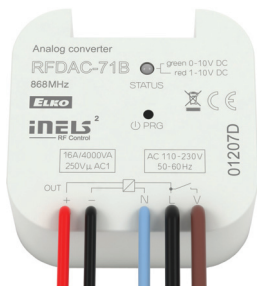

Technical parameters

RFDAC-71B

Supply voltage:	110–230 V AC
Supply voltage frequency:	50–60 Hz
Apparent input:	3 VA
Dissipated power:	1.2 W
Supply voltage tolerance:	+10/-15 %

Control

Potential-free analog output/max. current:	0(1)–10 V/10 mA
Rated current:	1x AgSnO ₂ , switches the phase conductor
Rated current:	16 A/AC1
Switching power:	4000 VA/AC1
Switching voltage:	250 V AC1
Mechanical service life:	3x10 ⁷
Electrical service life:	0.7x10 ⁵
Indication:	red LED/green LED
Output selection:	0(1)–10V/PROG button

Control

Wireless:	up to 25-channels (buttons)
Communication protocol:	RFIO2
Frequency:	866–922 MHz (for more information see p. 76)
Repeater function:	yes
Manual control:	button PROG (ON/OFF)
Range:	in open space up to 200 m
Minimal control distance:	20 mm

Other data

Operating temperature:	-15 to + 50 °C
Operating position:	any
Mounting:	plug into a socket
Protection:	IP30
Overvoltage category:	III.
Contamination degree:	2
Terminals (CY wire, cross-section):	3 x 0.75 mm ² , 2 x 2.5 mm ²
Length of terminals:	90 mm
Dimensions:	49 x 49 x 21 mm
Weight:	52 g
Related standards:	EN 60669, EN 300 220, EN 301 489 R&TTE Directive, Order. No 426/2000 Coll. (Directive 1999/EC)

- The device with analog output 0(1)–10 V is used to control devices, luminaires, thermal actuators and thermal heads – which are equipped with such an input.
- They can be combined with detectors, controllers, iNELS RF Control or system components.
- Potential free analog output 0(1)–10 V, contact relay 16 A.
- 6 light functions – smooth increase or decrease with time setting 2 s–30 min. Function description can be found on page 75.
- The analog controller may be controlled by up to 25-channels.
- The programming button on the controller is also used for manual control of the output.
- Memory status can be pre-set in the event of a power failure.
- Range up to 200 m (in open space), if the signal is insufficient between the controller and unit, use the signal repeater RFRP-20 or protocol component RFIO2 that support this feature.
- Communication frequency with bidirectional protocol RFIO2.
- The BOX design lets you mount it right in an installation box, a ceiling or light cover.

Device description

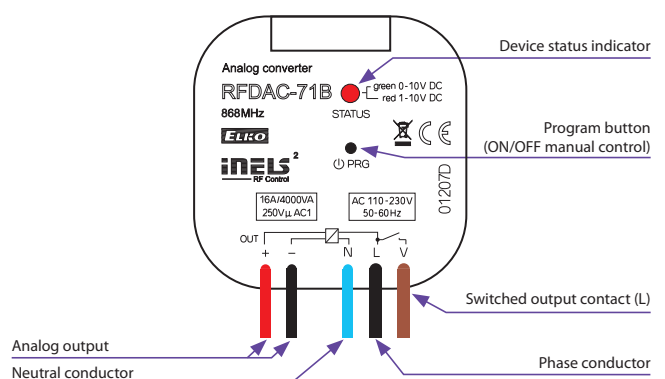

Connection

Connection example: dimming of fluorescent tubes with dimmable ballast

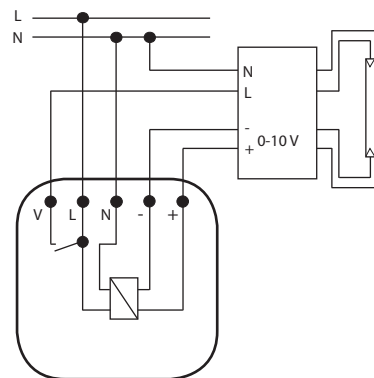

Connection example: with thermo valve

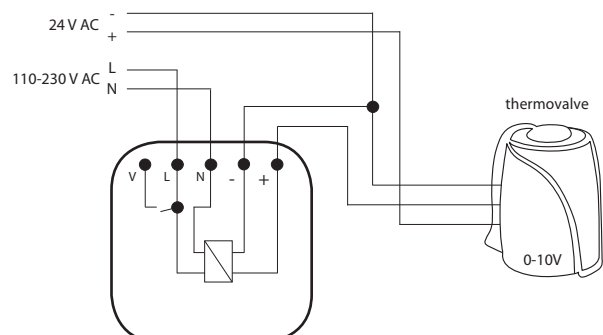



- The universal modular dimmer is used to regulate light sources:
 - R – classic lamps (resistive load)
 - L – halogen lamps with wound transformer (inductive load)
 - C – halogen lamps with electronic transformer (capacity load)
 - ESL – dimmable energy-efficient fluorescent lamps
 - LED – LED light sources equipped with LED.
- Control can be performed by:
 - a) detectors, Controllers and System units iNELS RF Control
 - b) by control signal 0(1)–10 V
 - c) potentiometer
 - d) existing button in the installation.
- 6 light functions – smooth increase or decrease with time setting 2 s–30 min. Function description can be found on page 75.
- Thanks to setting the min. brightness by potentiometer, you will eliminate flashing of the LED and ESL light sources.
- The universal dimmer may be controlled by up to 32-channels.
- The programming button on the controller is also used for manual control of the output.
- The package includes an internal antenna AN-I, in case of locating the unit in a metal switchboard, you can use the external antenna AN-E for better signal reception, see accessories on page 69.
- Memory status can be pre-set in the event of a power failure.
- Range up to 160 m (in open space), if the signal is insufficient between the controller and unit, use the signal repeater RFRP-20 or protocol component RFIO2 that support this feature.
- Communication frequency with bidirectional protocol RFIO2.
- The unit's 3-MODULE design with switchboard mounting.

Technical parameters	RFDEL-71M/230V	RFDEL-71M/120V
Supply voltage:	230 V AC	120 V AC
Supply voltage frequency:	50 Hz	60 Hz
Apparent power:	2.5 VA	1.1 VA
Dissipated power:	0.8 W	0.6 W
Supply voltage tolerance:	+10/-15 %	
Output		
Dimmed load:	R,L,C, LED, ESL	
Contactless:	2 x MOSFET	
Load capacity*:	max. 600 W	max. 300 W*
Control		
Wireless:	up to 32 channels (buttons)	
Communication protocol:	RFIO2	
Frequency:	866–922 MHz (for more information see p. 76)	
Repeater function:	yes	
Range:	in open space up to 160 m	
Manual control:	SW (ON/OFF) button	
External button:	max. 50 m cable	
Glow lamps connection:	no	
Analog control:	potentiometer or 0 (1)–10 V	
RF Antenna:	AN-I included (SMA connector**)	
Other data		
Operating temperature:	-20 to +35 °C	
Storage temperature:	-30 to +70 °C	
Operating position:	vertical	
Mounting:	DIN rail EN 60715	
Protection:	IP20 under normal conditions	
Overvoltage category:	II.	
Contamination degree:	2	
Cross-section of connecting wires:	max. 1x 2.5, max. 2x 1.5/with a hollow max. 1x 2.5	
Dimensions:	90 x 52 x 65 mm	
Weight:	125 g	
Related standards:	EN 607 30-1 ed.2	

* See page 75 for the load chart for each light source.

** Max. Tightening Torque for antenna connector is 0.56 Nm.

Device description

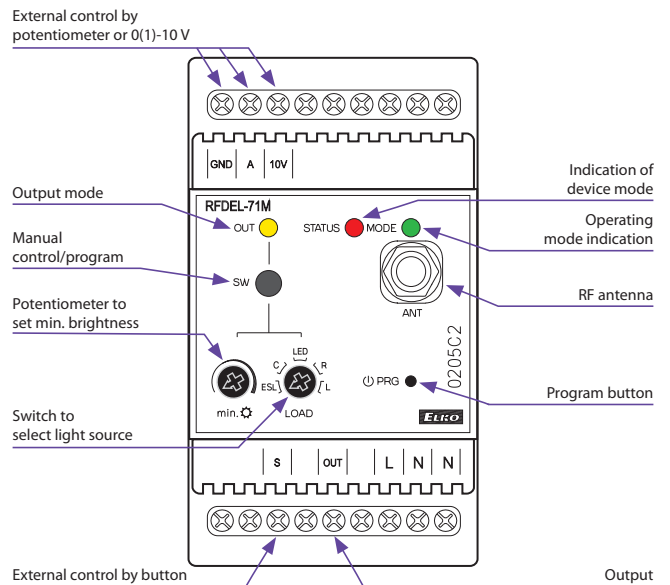

Connection and external control options

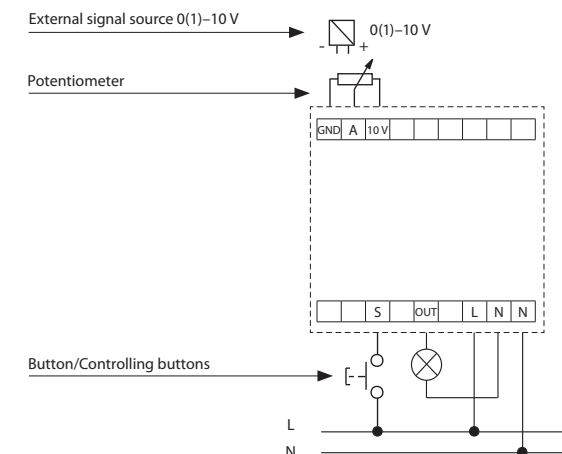



Technical parameters RFDEL-76M/230V RFDEL-76M/120V

Supply voltage:	230 V AC	120 V AC
Supply voltage frequency:	50 Hz	60 Hz
Power supply indication:	green LED Un	
Supply voltage tolerance:	+10/-15 %	

Output

Output:	12x MOSFET transistor	
Load type*:	R - resistive, L - inductive, C - capacitive, ESL - economical, LED	
Minimum output power:	10 VA	
Max. output power/channel:	150 VA	75 VA
Possible to connect outputs:	yes	
Maximum power when connecting all outputs:	max. 900 VA	max. 450 VA
Output protection:	thermal/short-term overload/longterm overload/short circuit	
Output indication:	red LED STATUS	

Control

Wired buttons:	potential "L" or external voltage AC 20–230 V (50–60 Hz)/DC 20–230 V
Wireless	up to 32-channels (with iNELS RF buttons)
Communication protocol:	RFIO2
Function repeater:	yes
Range:	in the open up to 160 m (524.11 ft)
RF antenna:	AN-I included (SMA connector)

Other information

Operating temperature:	-20 to +50 °C (-4 to 122 °F)
Storage temperature:	-30 to +70 °C (-22 to 158 °F)
Ingress protection:	IP20 under normal conditions
Overvoltage category:	II.
Contamination degree:	2
Connecting conductor:	max. 2.5 mm ² /1.5 mm ² with sleeve
Operating position:	vertical
Installation:	in the switchboard on DIN rail EN 60715
Design:	6-MODULE
Dimensions:	90 x 105 x 65 mm (3.5" x 4.1" x 2.6")
Weight	320 g (11 oz.)

*Warning: it is not allowed to simultaneously connect loads of inductive and capacitive type in the same channel.

Types of connectable loads

R resistive	L inductive	C capacitive	LED light	ESL saving

- RFDEL-76M is a universal 6-channels actuator, which is used to control the brightness intensity of dimmable sources R - L - C - LED - ESL.
- The maximum possible load is 150 VA for 230 V and 75 VA for 120 V for each channel.
- The individual channels of the dimmer can be connected in parallel and thus increase the maximum output load at the expense of the number of outputs.
- Each of the output channels is individually controllable and addressable.
- By setting the min. brightness eliminates flickering of different types of light sources, setting min. brightness and type of load is done using the PROG buttons.
- Electronic overcurrent, thermal and short-circuit protection, which switches off the output.
- 6 galvanically isolated inputs for wired buttons, which can be used to control the outputs independently of the RF.
- Communication with bidirectional RFIO2 protocol. The package includes an internal AN-I antenna, in case of placement of a sheet metal distribution element, you can use an external AN-E antenna to improve the signal.

Description

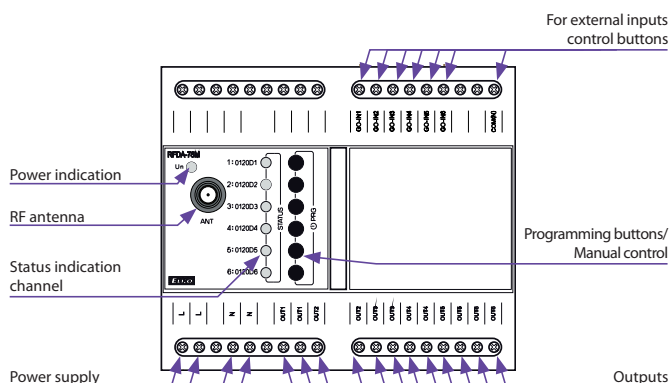

Connection

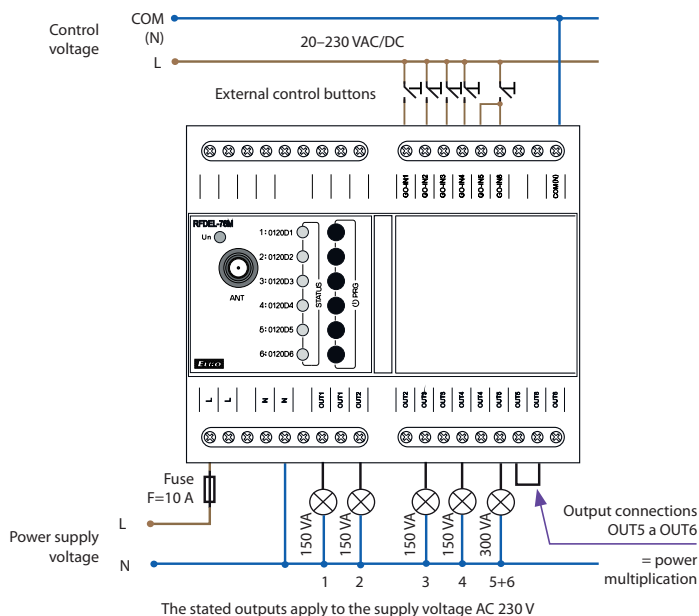

The stated outputs apply to the supply voltage AC 230 V



Technical parameters		RFDA-73M/RGB
Supply terminals:	Un+, GND	
Supply voltage:	12–24 V DC stabilized	
Maximum power without load:	0.8 W	
Output		
Dimmed load:	LED strip 12 V, 24 V with common anode RGB LED strips 12 V, 24 V with common anode	
Number of channels:	3	
Rated current:	3x5 A	
Peak current:	3x10 A	
Switching voltage:	Un	
Control		
Wireless:	up to 32-channels (buttons)	
Communication protocol:	RFIO2	
Frequency:	866–922 MHz (for more information see p. 76)	
Repeater function:	yes	
Load capacity of output +10 V:	10 mA	
Ext. signal:	0–10 V, 1–10 V	
Range:	in open space up to 160 m	
RF Antenna:	AN-I included (SMA connector*)	
Other data		
Operating temperature:	-20 to +50 °C	
Storage temperature:	-30 to +70 °C	
Working position:	any	
Mounting:	DIN rail EN 60715	
Protection:	IP20 from front panel	
Contamination degree:	2	
Cross-section of connecting wires (mm ²):	max. 1x 2.5, max. 2x 1.5/ with a hollow max. 1x 2.5	
Dimensions:	90 x 52 x 65 mm	
Weight:	130 g	
Related standards:	EN 60730-1; EN 60730-2-11	

* Max Tightening Torque for antenna connector is 0.56 Nm.

- The dimmer for LED strips is used for independent control of 3 single-colour LED strips or one RGB LED strip.
- The expanded selection of control modes enables it to be combined with:
 - a) detectors, controllers and system units iNELS RF Control
 - b) device with output signal 0 (1)–10 V
 - c) potentiometer.
- The unit's 3-MODULE design with switchboard mounting enables connection of dimmed load 3x 5 A, which represents:
 - a) single-colour LED strip 7.2 W – 3x 8 m
 - b) RGB LED strip 14.2 W–10 m.
- 6 light functions – smooth increase or decrease with time setting 2 s – 30 min. Function description can be found on page 75.
- The dimmer may be controlled by up to 32-channels.
- The power supply of the unit is in the range of 12–24 V DC, and is indicated by a green LED.
- The package includes an internal antenna AN-I, in case of locating the unit in a metal switchboard, you can use the external antenna AN-E for better signal reception, see accessories on page 75.
- Memory status can be pre-set in the event of a power failure.
- Range up to 160 m (in open space), if the signal is insufficient between the controller and unit, use the signal repeater RFRP-20 or protocol component RFIO2 that support this feature.
- Communication frequency with bidirectional protocol RFIO2.

Device description

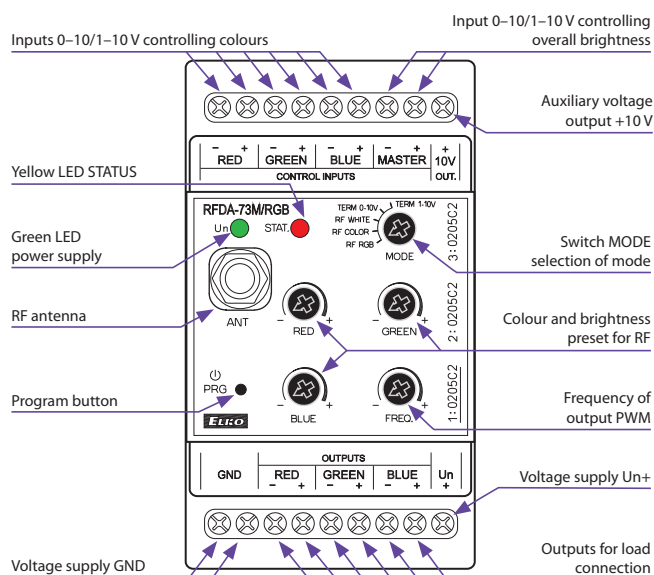

Output variations and external control options

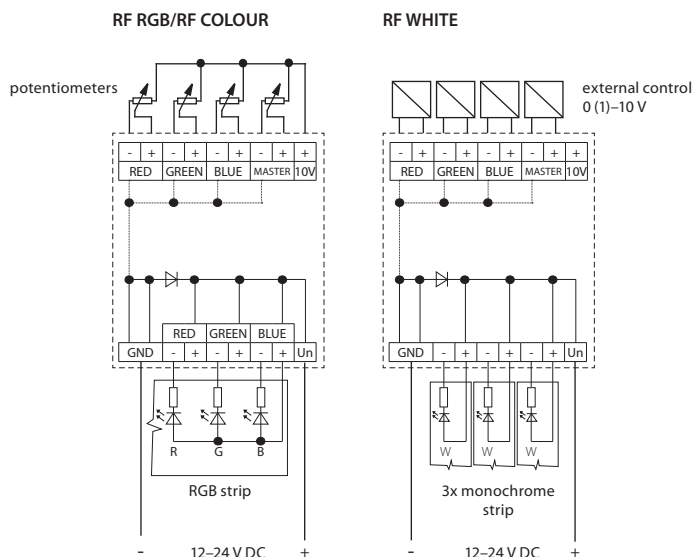

Control modes

RF RGB

Switch settings in MODE:

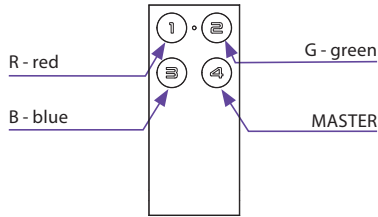
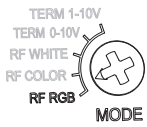

RF RGB mode for controlling RGB LED strips. In the RF RGB programming mode, colours are automatically assigned to individual transmitter buttons.

Note: The mode can be controlled by RF Touch, RF Pilot, RFWB-40/G, RF KEY, RFIM-40B and eLAN-RF.

RF Color

Switch settings in MODE:

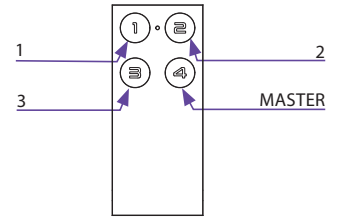
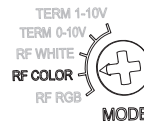

RF COLOUR mode for controlling RGB LED strips, where you can choose the colour for individual transmitter buttons. A long press of the button starts the colour search mode. After releasing the button, the current colour is set for the given button.

Note: The mode can be controlled by RF Touch, RF Pilot, RFWB-40/G, RF KEY, RFIM-40B and eLAN-RF.

RF WHITE

Switch settings in MODE:

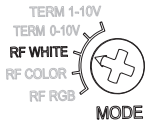

This works in a mode where it acts like three independent dimmers for 12–24 V. Each channel can be programmed independently of one another and has its own address.

Note: The mode can be controlled by RF Touch, RF Pilot, RFWB-20/G, RFWB-40/G, RF KEY, RFIM-20B, RFIM-40B and eLAN-RF.

TERM 0–10 V and TERM 1–10 V

Switch settings in MODE:

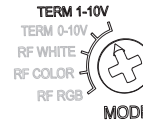
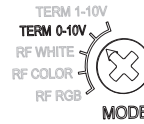

Modes TERM 0–10 V and TERM 1–10 V. Inputs 0–10 V and 1–10 V used to control one RGB LED strip or three independent single-colour LED strips (see modes above) from the iNELS BUS System. For controlling, you can use the application iMM on the TV screen or the application iHC for smartphones and tablets.

Control options

TERM 0(1)–10 V DC - monochrome LED strips

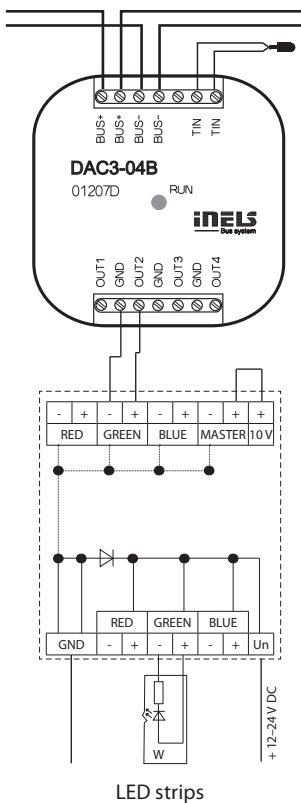

TERM 0(1)–10 V DC - RGB LED strips

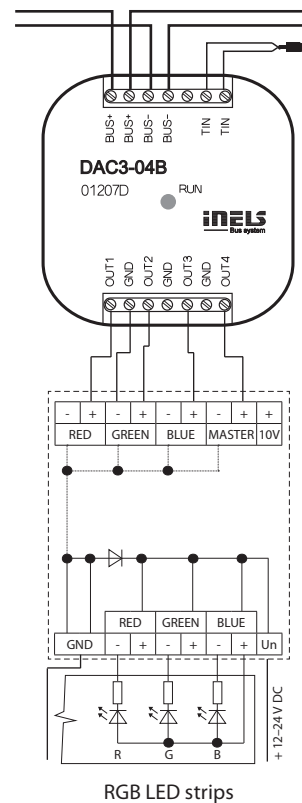



Technical parameters RFDSC-71/230V RFDSC-71/120V

Supply voltage:	230–250 V	120 V AC
Supply voltage frequency:	50–60 Hz	60 Hz
Apparent power:	1.1 VA	
Dissipated power:	0.8 W	
Supply voltage tolerance:	+10/-15 %	

Output

Contactless:	2 x MOSFET	
Load capacity:*	max. 300 W	max. 150 W
Dimming load:	R, L, C, LED, ESL	

Control

Wireless:	up to 32-channels (buttons)
Communication protocol:	RFIO
Frequency:	866–922 MHz (for more information see p. 76)
Repeater function:	no
Range:	in open space up to 160 m
Manual control:	button PROG (ON/OFF)

Other data

Operating temperature:	-20 to +35 °C
Storage temperature:	-30 to +70 °C
Working position:	any
Mounting:	plug into a socket
Protection:	IP30
Overvoltage category:	III.
Contamination degree:	2
Dimensions:	60 x 120 x 80 mm
Weight:	131 g
Related standards:	EN 60669, EN 300 220, EN 301 489 R&TTE Directive, Order. No 426/2000 Coll. (Directive 1999/EC)

* See page 75 for the load chart for each light source.

- The dimmed socket is used to control light sources that are connected by power cord - especially lamps:
 - R – classic lamps (resistive load)
 - L – halogen lamps with wound transformer (inductive load)
 - C – halogen lamps with electronic transformer (capacity load)
 - ESL – dimmable energy-efficient fluorescent lamps
 - LED – LED light sources equipped with LED.
- Multi-function 6 light functions – smooth increase or decrease with time setting 2 s – 30 min. Function description can be found on page 75.
- Thanks to setting the min. brightness by potentiometer, you will eliminate flashing of the LED and ESL light sources.
- The universal dimmer may be controlled by up to 32-channels.
- The programming button on the socket is also used for manual control of the output.
- Memory status can be pre-set in the event of a power failure.
- Range up to 160 m (in open space), if the signal is insufficient between the controller and unit, use the signal repeater RFRP-20 or protocol component RFIO2 that support this feature.
- Communication frequency with bidirectional protocol RFIO.

Produced in 3 designs of sockets/plugs:



Device description

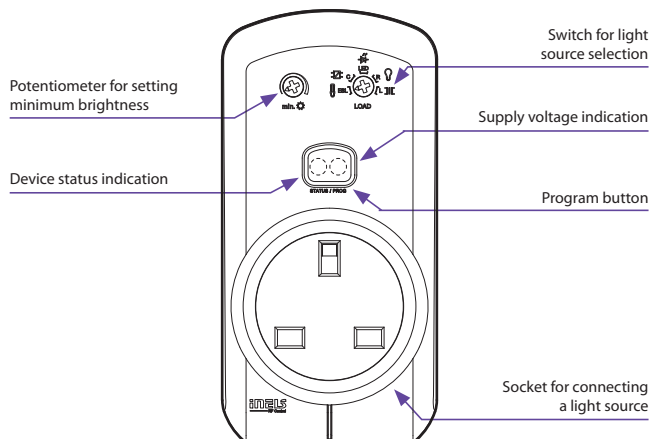

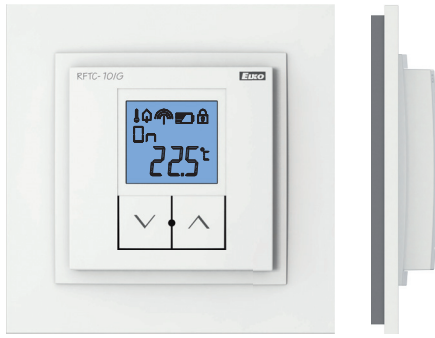

- RFTC-10/G is used for temperature measurement (in the range of 0 to 55 °C) and correction of the pre-set temperature in RF Touch or eLAN-RF system devices in the range of ± 5 °C. The temperature correction is valid until the next program change in the given system device.
- The backlit LCD display displays the current and set temperature, status (ON/OFF), battery status, etc.
- Range up to 100 m (in open space), if the signal is insufficient between the controller and unit, use the signal repeater RFRP-20 or protocol component RFIO2 that support this feature.
- Communication frequency with bidirectional protocol RFIO.
- Colour combination of heating unit in design of frames LOGUS⁹⁰ (plastic, glass, wood, metal, stone).

Technical parameters		RFTC-10/G
Supply voltage:	2 x 1.5 V AAA batteries	
Battery life:	1 year based on frequency of use	
Temperature correction:	2 buttons ∇/∧	
Temperature offset:	± 5 °C	
Display:	LCD, characters/see Display description	
Backlighting:	active 10 s after pressing	
Transmission indication/function:	symbols	
Temperature measurement:	1x internal sensor	
Temp. measurement range and accuracy:	0 to +55 °C; 0.3 °C of the range	
Control		
Communication protocol:	RFIO	
Frequency:	866–922 MHz (for more information see p. 76)	
Repeater function:	no	
Signal transmission method:	bidirectionally addressed message	
Range:	in open space up to 100 m	
Minimum control distance:	20 mm	
Other data		
Max. number of control.	1	
RFSA-6x:	x	
Program:	x	
Operating temperature:	0 to +55 °C	
Operating position:	wall-mounted	
Mounting:	glue/screws	
Protection:	IP30	
Contamination degree:	2	
Dimensions frame		
- plastic:	85 x 85 x 20 mm	
- metal, glass, wood, granite:	94 x 94 x 20 mm	
Weight:	66 g (without batteries)	
Related standards:	EN 60669, EN 300 220, EN 301 489 R&TTE Directive, Order. No 426/2000 Coll. (Directive 1999/EC)	

Device description

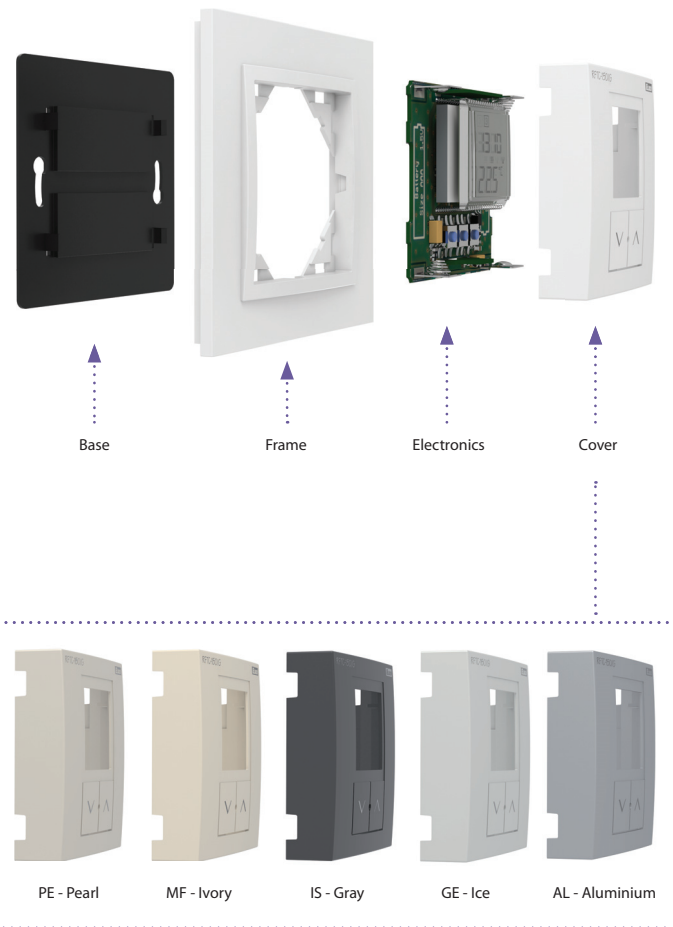

Compatibility				
RF Touch	eLAN-RF	RFSA-6 x	RFSTI-11B	RFATV-1
✓	✓	✓	-	-

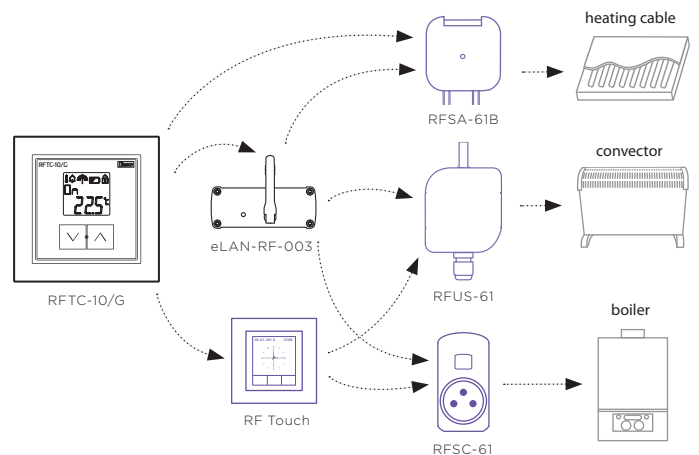
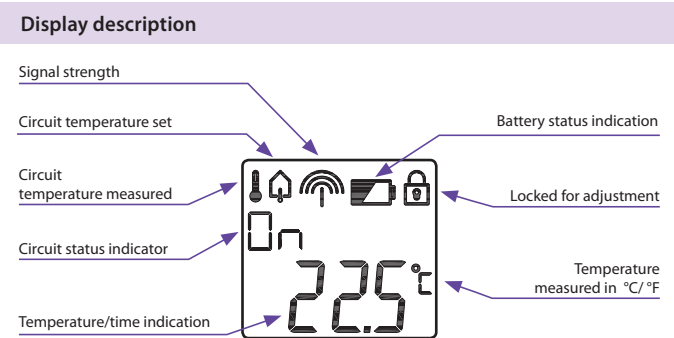



- RFTC-50/G is a separate thermostat that allows wireless control of up to 4 multifunctional switching components, e.g. RFSA-6x, RFUS-61, RFSTI-11B.
- Temperature measurement with built-in sensor in the range of 0.55 °C, temperature setting in the range of 0 to +55 °C in the weekly program.
- The backlit LCD display displays the current and set temperature, status (ON/OFF), battery status, day of the week, current time, etc.
- Battery power (2x 1.5 V AAA batteries - included in supply) with battery life of around 1 year based on frequency of use.
- Range up to 100 m (in open space), if the signal is insufficient between the controller and unit, use the signal repeater RFRP-20 or protocol component RFIO2 that support this feature.
- Communication frequency with bidirectional protocol RFIO.
- Colour combination of temperature unit in design of frames LOGUS⁹⁰ (plastic, glass, wood, metal, stone).

Technical parameters

RFTC-50/G

Supply voltage:	2x 1.5 V AAA batteries
Battery life:	1 year based on frequency of use according to the number of controlling actuators
Temperature correction:	2 buttons ∇ / ▲
Temperature offset:	± 5 °C
Display:	LCD, characters/see Display description
Backlighting:	active 10 s after pressing
Transmission indication/function:	symbols
Temperature measurement:	1x internal sensor
Temp. measurement range and accuracy:	0 to +55 °C; 0.3 °C of the range

Control

Communication protocol:	RFIO
Frequency:	866–922 MHz (for more information see p. 76)
Repeater function:	no
Signal transmission method:	bidirectionally addressed message
Range:	in open space up to 100 m
Minimum control distance:	20 mm

Other data

Max. number of control.	
RFSA-6x:	4
Program:	Weekly
Operating temperature:	0 to + 55 °C
Operating position:	on the wall
Mounting:	by gluing/screwing
Protection:	IP30
Contamination degree:	2
Dimensions frame	
- plastic:	85 x 85 x 20 mm
- metal, glass, wood, granite:	94 x 94 x 20 mm
Weight:	66 g (without batteries)
Related standards:	EN 60669, EN 300 220, EN 301 489 directive R&TTE Directive, Order. No 426/2000 Coll. (Directive 1999/EC)

Compatibility

RF Touch	eLAN-RF	RFSA-6 x	RFSTI-11B	RFATV-1
-	-	✓	✓	-

Display description

Displaying the day of the week

Displaying the time

Indication of manual mode

Displaying the temperature

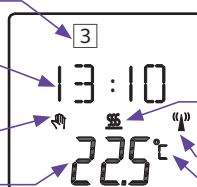

The heating function switched output

Indicates the state of connection with actuators

Temperature units °C

Device description

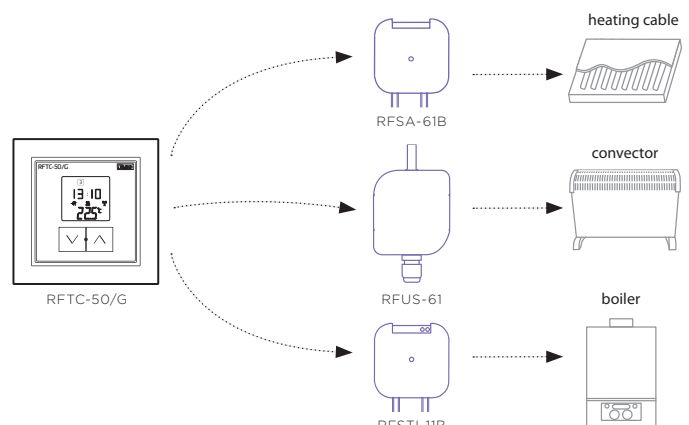
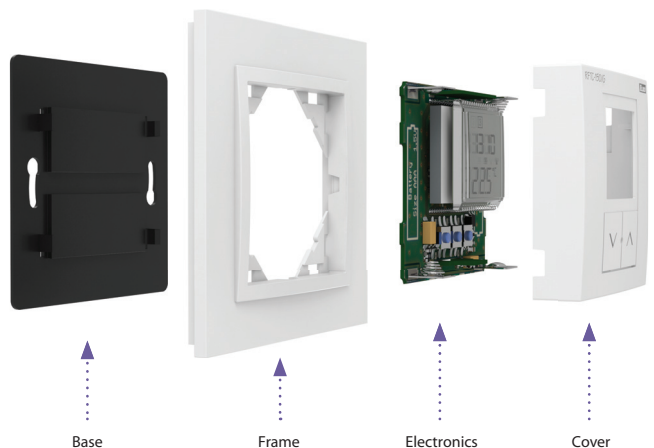



- The temperature unit measures the temperature by external sensor, and controls the heating circuit (electric underfloor heating, air conditioning, boiler, etc.).
- These can be combined with system units: smart RF box eLAN-RF, wireless controller RFTC-50/G or touch unit RF Touch.
- It measures temperature in a range of -20 to 50 °C and sends it to the system unit in regular 5 min. intervals. It sends a signal upon sudden temperature change.
- Setting the heat/cool function, hysteresis and offset is performed in the system unit or application.
- It enables connection of the switched load up to 16 A (4 000 W).
- Range up to 160 m (in open space), if the signal is insufficient between the controller and unit, use the signal repeater RFRP-20 or protocol component RFIO2 that support this feature.
- Communication frequency with bidirectional protocol RFIO2.
- The BOX design lets you mount it right in an installation box, a ceiling or controlled appliance cover.
- External sensor TC (-20 to +80 °C) or TZ (-40 to +125 °C) for length of 3 m, 6 m, 12 m. For more information see „Accessories“ on page 43.

Technical parameters	RFSTI-11B/230V	RFSTI-11B/120V	RFSTI-11B/24V
Supply voltage:	230 V AC	120 V AC	12–24 V AC/DC
Supply voltage frequency:	50–60 Hz	60 Hz	50–60 Hz
Apparent input:	7 VA/cos φ= 0.1		-
Dissipated power:	0.7 W		
Supply voltage tolerance:	+10 %; -15 %		
Temperature measurement input:	1x external TZ/TC temperature sensor input		
Temp. measurement range and accuracy:	-20 to +50 °C; 0.5 °C of the range		
Output			
Number of contacts:	1x switching (AgSnO ₂)		
Rated current:	16 A/AC1		
Switching power:	4000 VA/AC1, 384 W/DC		
Peak current:	30 A/<3 s		
Switching voltage:	250 V AC1/24 V DC		
Max. DC switching power:	500 mW		
Mechanical service life:	3x10 ⁷		
Electrical service life (AC1):	0.7x10 ⁵		
Control			
Communication protocol:	RFIO2		
Frequency:	866–922 MHz (for more information see p. 76)		
Repeater function:	yes		
Range:	in open space up to 160 m		
Other data			
Operating temperature:	-15 to +50 °C		
Status indication:	red LED		
Operating position:	any		
Mounting:	free at lead-in wires		
Protection:	IP30		
Overvoltage category:	III.		
Contamination degree:	2		
Outlets (CY wire, cross-section, length):	2 x 0.75 mm ² , 2 x 2.5 mm ² , 90 mm		
Dimensions:	49 x 49 x 21 mm		
Weight:	46 g		
Related standards:	EN 60669, EN 300 220, EN 301 489 R&TTE Directive, Order. No 426/2000 Coll. (Directive 1999/EC)		

Device description

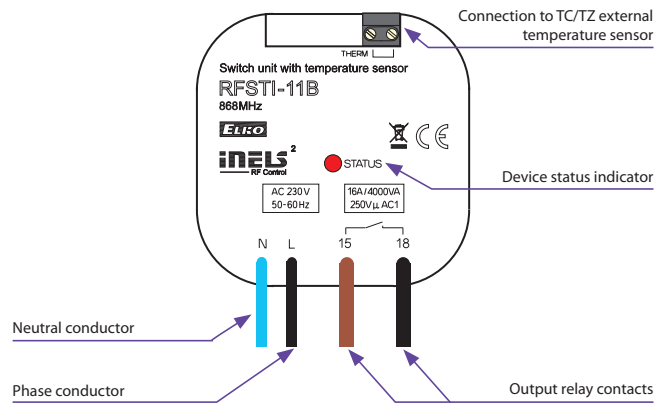

Connection

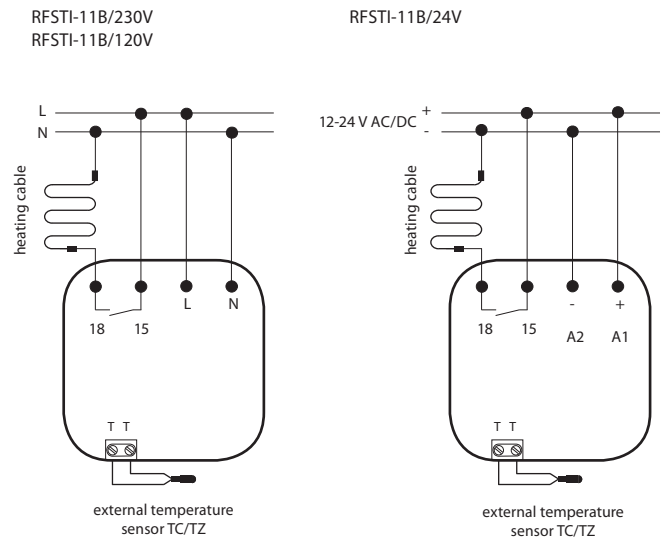

Temperature sensor input is at the supply voltage potential.



- It measures temperature in a range of -20 to 50 °C with internal or external sensor and sends it to the system unit (eLAN-RF, RF-Touch) in regular 5 min. intervals.
- It sends a signal upon sudden temperature change within 1 min.
- Option of connecting an external sensor to the terminals THERM.
- Battery power (1x 3 V CR 2477 battery - included in supply) with battery life of around 1 year based on frequency of use.
- Range up to 160 m (in open space), if the signal is insufficient between the controller and unit, use the signal repeater RFRP-20 or protocol component RFIO2 that support this feature.
- Communication frequency 868 MHz with bidirectional protocol RFIO.
- External sensor TC (-20 to +80 °C) or TZ (-40 to +125 °C) for length of 3 m, 6 m, 12 m. For more information see „Accessories“ on page 45.

Technical parameters

RFTI-10B

Supply voltage:	1x 3 V CR 2477 battery
Battery life:	1 year based on frequency of use
Transmission indication/function:	red LED
Temperature measurement:	1x internal NTC thermistor 1x external TZ/TC temperature sensor input
Temp. measurement range and accuracy:	-20 to +50 °C; 0.5 °C in the range

Output

Communication protocol:	RFIO
Frequency:	866–922 MHz (for more information see p. 76)
Repeater function:	no
Signal transmission method:	unidirectionally addressed message
Range:	in open space up to 160 m

Other data

Operating temperature:	-10 to +50 °C
Operating position:	any
Mounting:	glued/free-standing
Protection:	IP30
Contamination degree:	2
Dimensions:	49 x 49 x 13 mm
Weight:	45 g
Related standards:	EN 60669, EN 300 220, EN 301 489 R&TTE Directive, Order. No 426/2000 Coll. (Directive 1999/EC)

Device description

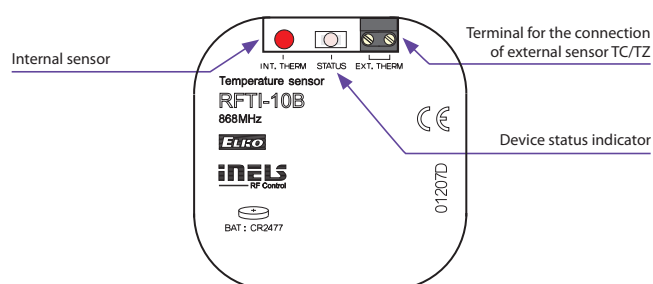

Sensor location

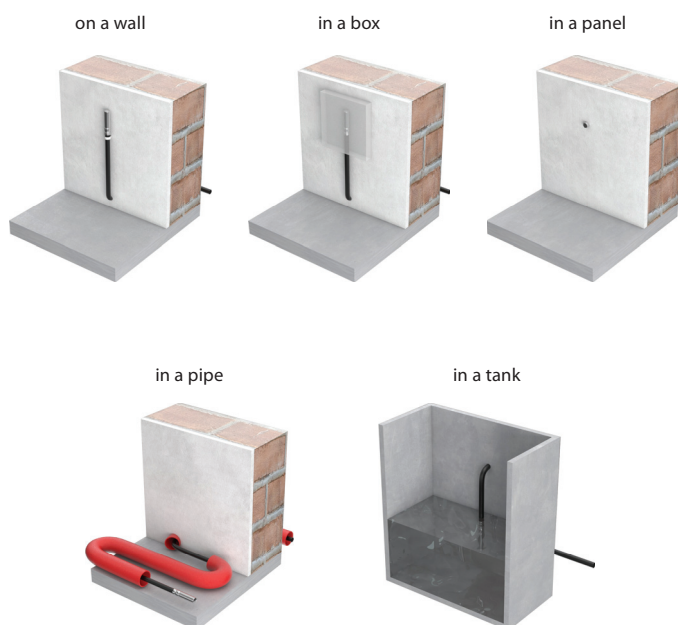

TC, TZ | Temperature sensors



- Thermister temperature sensors are made of Negative Temperature Coefficient (NTC) embedded in a PVC or metal sleeve with a thermally-conductive sealer.
- **Sensor TC**
- lead-in cable to sensor TC is made of wire CYSY 2D x 0.5 mm/0.02".
- **Sensor TZ**
- cable VO3SS-F 2D x 0.5 mm/0.02" with silicone insulation for use in high temperature applications.
- silicone insulation for use in high temperature applications.
- Temperature sensors can be connected directly to the terminal block
- Cable lengths can not be changed, connected or modified.

Technical parameters	TC	TZ
Range:	-20 to +80 °C (-4 to 176 °F)	-40 to +125 °C (-40 to 257 °F)
Scanning element:	NTC 12K	NTC 12K
Tolerance:	±(0.15 °C + 0.002 t)	±(0.15 °C + 0.002 t)
In air/in water:	(τ0.5) ≤ 18 s	(τ65) 62 s/8 s
In air/in water:	(τ0.9) ≤ 48 s	(τ95) 216 s/23 s
Cable material:	PVC unshielded, 2x 0.25 mm ²	silicon VO3SS-F 2D x 0.5 mm ²
Terminal material:	polyamide	stainless steel
Protection degree:	IP67	IP67
Electrical strength:	2500 VAC	2500 VAC
Insulation resistance:	> 200 MΩ at 500 VDC	> 200 MΩ at 500 VDC

Types of temperature sensors:		
	TC-0	TZ-0
- length:	100 mm	110 mm
- weight:	5 g	4.5 g
	TC-3	TZ-3
- length:	3 m	3 m
- weight:	70 g	106 g
	TC-6	TZ-6
- length:	6 m	6 m
- weight:	130 g	216 g
	TC-12	TZ-12
- length:	12 m	12 m
- weight:	250 g	418 g

τ65 (95): time, which sensor needs to heat up on 65 (95) % of ambient temperature of environment, in which is located.

Resistive values of sensors in dependance on temperature

Temperature (°C)	Sensor NTC (kΩ)
20	14.7
30	9.8
40	6.6
50	4.6
60	3.2
70	2.3

Tolerance of sensor NTC 12 kΩ is ± 5% by 25 °C/77 °F.

Diagramm of sensor warm up via air

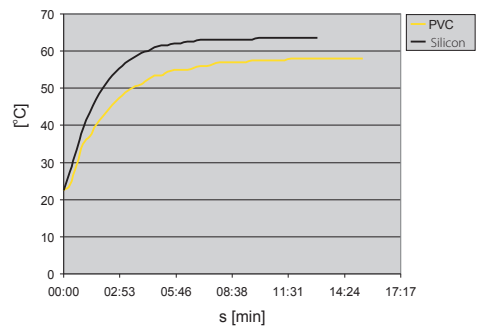

PVC -reaction to water temperature from 22.5 °C to 58 °C.
Silicone - reaction to water temperature from 22.5 °C to 63.5 °C.

Design and dimensions

TC

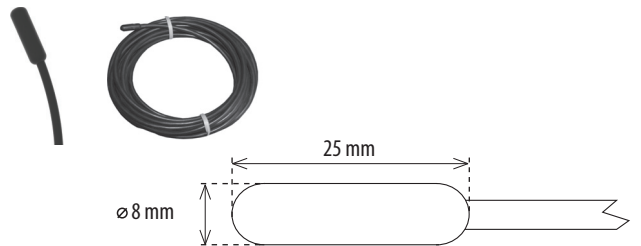

TZ

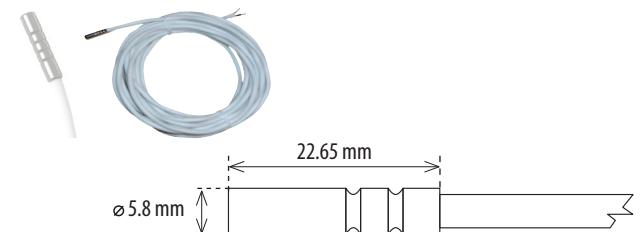



Technical parameters	TELVA 230V		TELVA 24V	
	NO	NC	NO	NC
Operating voltage:	230 V, 50/60 Hz		24 V, 50/60 Hz	
Switching current max:	300 mA		500 mA	
Operating current:	13 mA		100 mA	
Closing/opening time:	3–5 min		3–5 min	
Power input:	2.9 W		2.4 W	
Protection:	IP54		IP54	
Settings:	4 mm (0.16")		4 mm (0.16")	
Stopping force:	90–110 N		90–110 N	
Cable length:	800–1000 mm (31–39")		800–1000 mm (31–39")	
Connecting wire:	2 x 0.75 mm ²		2 x 0.75 mm ²	
Media temperature:	-5 °C to 60 °C (23 to 140 °F)		-5 °C to 60 °C (23 to 140 °F)	
Colour:	white RAL 9003		white RAL 9003	
Dimensions h/w/d:	63 x 42 x 45 mm (2.5 x 1.7 x 1.8")		63 x 42 x 45 mm (2.5 x 1.7 x 1.8")	
Connection size:	M30 x 1.5 mm (1.2" x 0.06")		M30 x 1.5 mm (1.2" x 0.06")	

- Thermodrive is intended for opening or closing valves in heating, cooling or air conditioning systems. It is also suitable for use in a floor heating or ceiling cooling manifolds.
- Available in NO (open without voltage), NC (closed without voltage) and for 230 V and 24 V.
- The internal principle of operation of thermodrive mechanism = its movement so that the valve opens/closes is provided by an electric heating element with expansion material, which expands due to temperature changes in the supply voltage.
- Thermodrive is maintenance-free and works completely silently.
- Thermodrive is fitted with a metal nut M30 x 1.5, thanks to which it becomes a 100% fixed part of the valve with this corresponding thread size after installation.
- The stated nut size predetermines the use of a thermocouple with valves from manufacturers such as Herz, HoneyWell, Danfoss, Oventrop and others.

• Telva thermo drive:

- is characterized by absolutely quiet and maintenance-free operation
- is designed for installation - control of heating and cooling systems
- method of mounting the actuator on the controlled valve using an M30 x 1.5 nut
- any working position

• Type of use:

- Floor heating – the RFTC-50/G wireless controller measures the room temperature and, based on the set program, sends a command to the RFSA-66M switching element to open/close the TELVA thermo drive on the distributor.



- **RFIM-20B:** the wireless contact converter changes your existing wired button/switch to a wireless one.
 - two inputs enable control of two units independent,
 - battery power supply (1x 3 V CR 2477 battery - included in the supply) with battery life of around 5 years based on frequency of use,
 - contact can be permanently closed (does not drain on the battery).
- **RFIM-40B:** the wireless contact converter changes your existing wired button to a wireless one.
 - four inputs enable control of four units independently,
 - battery power supply (2x 3 V CR 2032 batteries) with battery life of around 5 years based on frequency of use (included in the supply),
 - button control (input must not be permanently closed).
- It can be used to transmit information on switching on the contact (detector, button, technology, logic output).
- When pressing the button, it sends a set signal (ON/OFF, dimming, time switching OFF/ON, blinds up/down).
- Option of setting light scenes, where with a single press, you can control multiple units of iNELS RF Control.
- Range up to 200 m (in open space), if the signal is insufficient between the controller and unit, use the signal repeater RFRP-20 or protocol component RFIO2 that support this feature.
- Communication frequency with bidirectional protocol RFIO.
- The BOX design lets you mount it right in an installation box under the button or switch.

Technical parameters	RFIM-20B	RFIM-40B
Supply voltage:	1x 3 V CR 2477 battery	2x 3 V CR 2032 batteries
Battery life:	5 years based of frequency use	
Transmission indication / function:	orange LED	red LED
Number of inputs:	2	4
Input switching time:	Permanent input connection (contact)	Short-tem input connection (button)
Control		
Communication protocol:	RFIO	
Frequency:	866–922 MHz (for more information see p. 76)	
Repeater function:	no	
Signal transmission method:	unidirectionally addressed message	
Range:	in open space up to 200 m	
Other data		
Operating temperature:	-10 to +50 °C	
Operating position:	any	
Terminals (CY wire, cross-section):	4 x 0.75 mm ²	6 x 0.75 mm ²
Length of terminals:	90 mm	
Resist.of connection between terminals		
- for switched on button:	< 300 Ω	
- for disconnected contact:	> 10 kΩ	
Mounting:	free at lead-in wires	
Protection:	IP30	
Contamination degree:	2	
Dimensions:	49 x 49 x 13 mm	
Weight:	45 g	50 g
Open contact voltage:	pulse 12 V	3 V
Length of cable to contact:	max. 100 m of parallel lines	max. 5 m
Related standards:	EN 60669, EN 300 220, EN 301 489 R&TTE Directive, Order. No 426/2000 Coll. (Directive 1999/EC)	

Device description

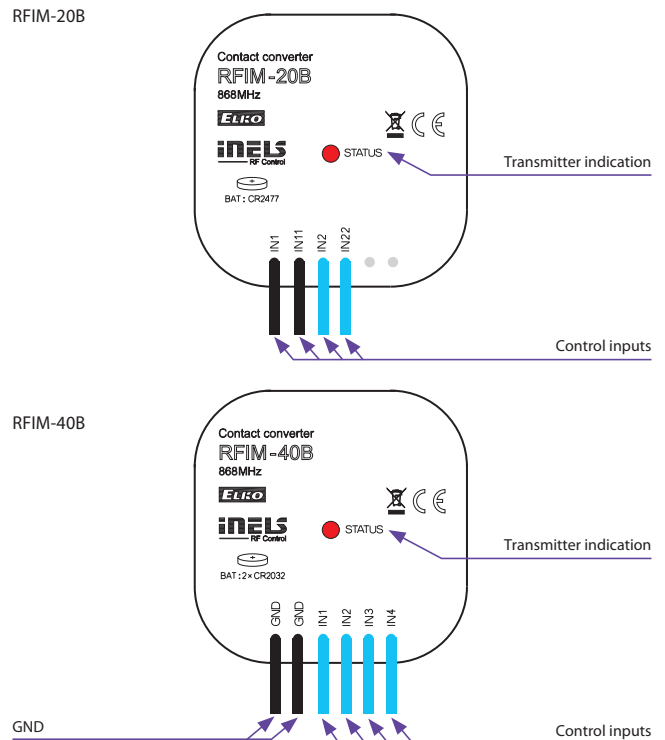

Connection

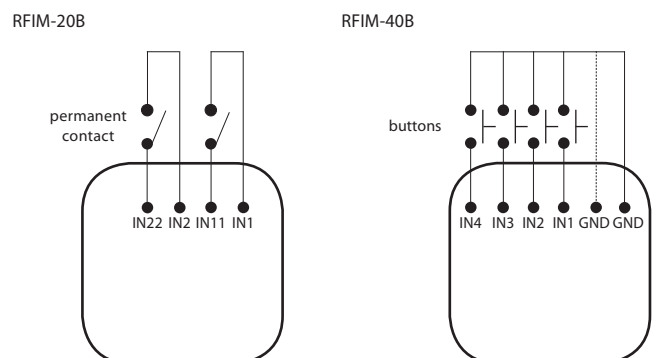



Technical parameters	RFSG-1M
Supply voltage:	110–230 V AC
Supply voltage frequency:	50–60 Hz
Apparent input:	2 VA
Dissipated power:	0.2 W
Supply voltage tolerance:	+10 %/-25 %
Power supply indication:	green LED
Input	
Control voltage:	AC 12–230 V/DC 12–230 V
Control input power:	AC 0.025 VA/DC 0.1 W
Control terminals:	S–S
The length of control impulse:	min. 25 ms (max. unlimited)
Transmission indication/function:	red LED
Control	
Communication protocol:	RFIO
Frequency:	866–922 MHz (for more information see p. 76)
Repeater function:	no
Signal transmission method:	unidirectionally addressed message
Range:	in open space up to 160 m
Minimum control distance:	20 mm
RF antenna:	AN-I included (SMA connector)*
Other data	
Operating temperature:	-15 to +50 °C
Operating position:	any
Mounting:	DIN rail support EN 60715
Protection:	IP20 from the front panel
Overvoltage category:	III.
Contamination degree:	2
Connecting conductor cross-section: (mm ²):	max. 1x 2.5, max. 2x 1.5/ with a hollow max. 1x 2.5
Dimensions:	90 x 17.6 x 64 mm
Weight:	62 g
Related standards:	EN 60669, EN 300 220, EN 301 489 R&TTE Directive, Order. No 426/2000 Coll. (Directive 1999/EC)

* Max Tightening Torque for antenna connector is 0.56 Nm.

- This wireless contact converter is especially appropriate for wireless transmission of information on switching HDO.
- Thanks to the permanent power supply, it can also be used for partial transmission of information for control of an appliance or device.
- After leading in power to the "S" terminals, it periodically transmits the command switch on in an interval of 10 min. When disconnecting the power supply, immediately switch off.
- The button TEST on the controller is used to assign to a switching unit.
- The package includes an internal antenna AN-I, in case of locating the converter in a metal switchboard, you can use the external antenna AN-E for better signal reception, see accessories on page 69.
- Range up to 160 m (in open space), if the signal is insufficient between the controller and unit, use the signal repeater RFRP-20.
- Communication frequency with bidirectional protocol RFIO.
- 1-MODULE design of the unit with mounting into switchboard.

Device description

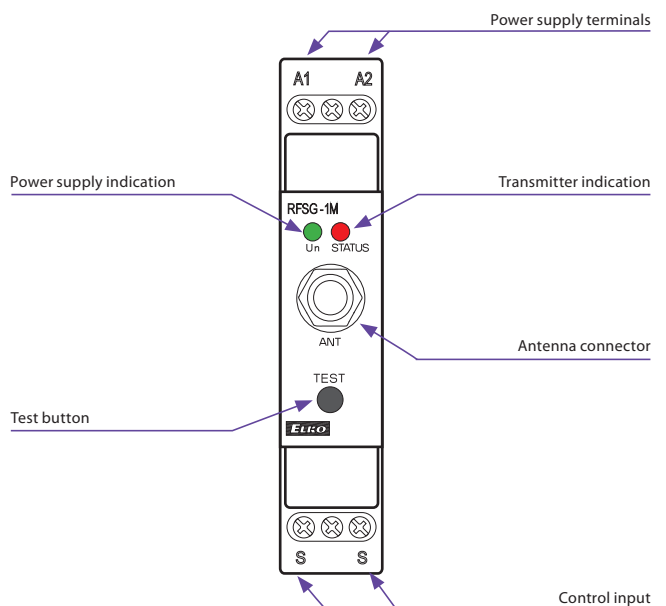

Connection

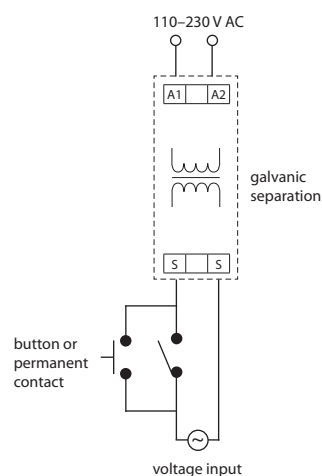



Technical parameters

RFSF-1B

Supply voltage:	1x 3 V CR 2477 battery
Battery life:	1 year based on frequency use
Indications/transfer function:	red LED
Reset after flooding:	JUMPER - Manual/Automatic
Programming:	with Prog button/based batteries
Measuring input:	terminal 0.5–1mm ²
Voltage measuring input:	3 V
Resistance measuring input for detecting flooding:	≤20 kΩ
Resistance measuring input for flushing detection:	≥40kΩ
Probe cable length:	max. 30 m

Control

Communication protocol:	RFIO
Frequency:	866–922 MHz (for more information see p. 76)
Repeater function:	no
Signal transmission method:	two-way addressed message
Range:	in open space up to 160 m

Other data

Working temperature:	-10 to +50 °C
Operating position:	any
Mounting:	glue/freely
Protection:	IP30
Degree of pollution:	2
Dimensions:	49 x 49 x 13 mm
Weight:	45 g
Standards:	EN 60730-1, EN 300 220, EN 301 489 directive R&TTE Directive, Order. No 426/2000 Coll. (Directive 1999/EC)

- Monitors areas (e.g. bathrooms, basements, shafts or tanks) to provide flood warning.
- Upon detecting water, the flood detector immediately sends a signal to the switched unit, which further switches on a pump, GSM gate or closes a pipe valve.
- The programming button on the detector is used to:
 - a) setting the function with switching unit
 - b) ascertaining battery status
 - c) ascertaining signal quality between the unit and detector.
- Battery power supply (1x 3 V CR 2477 battery - included in the supply) with battery life of around 1 year based on frequency of use.
- The detector can be placed anywhere thanks to battery power.
- Range up to 160 m (in open space); if the signal is insufficient between the controller and unit, use the signal repeater RFRP-20 or protocol component RFIO2, that support this feature.
- Communication frequency with bidirectional protocol RFIO.
- Option of connecting an external probe FP-1, max. wire length 30 m.

Device description

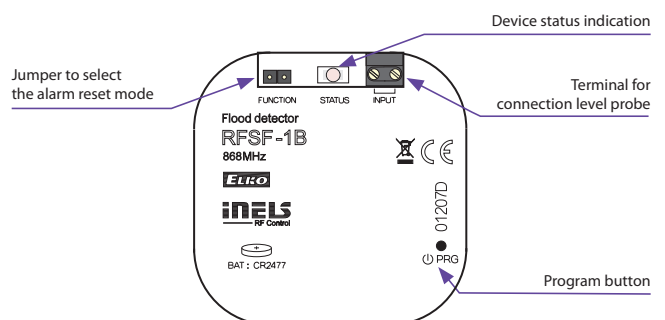

Location of the detector and probe

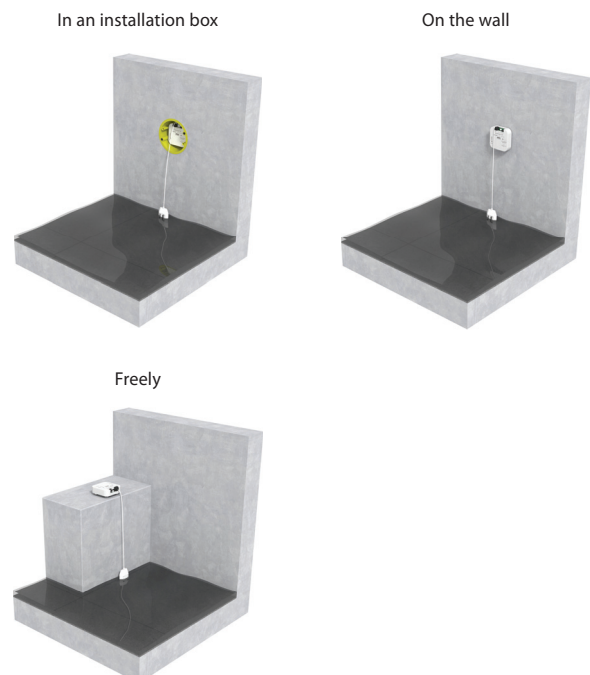

FP-1 | Liquid probe



Technical parameters

FP-1

Working temperature:	-10 to +40 °C
Mounting:	glue/screws
Length of cable:	1 m
Dimensions:	18 x 8 x 26 mm



- The flood detector is used to detect water leakage - the activation occurs the moment the flooding of the contacts located on the underside of the detector occurs.
- Upon detecting water, the flood detector immediately sends a signal to the switched unit, which further switches on a pump, GSM gate or closes a pipe valve.
- Flood detection is signalled by optical and acoustic signalling.
- Range up to 160 m (in open space); if the signal is insufficient between the controller and unit, use the signal repeater RFRP-20 or protocol component RFIO2 that support this feature.

Technical parameters		RFSF-100
Power supply		
Battery power:	2x 1.5 V AAA batteries	
Battery life by frequency	3 years	
1x 12 hours:		
Setting		
Alarm Detection:	optical and audible alarm	
Battery status view:	low battery is indicated by 5 flashes every 15 minutes or by display in the system element	
Acoustic signal:	greater than 45 dB/1m	
Detection		
Sensor:	contacts for flooding	
Detection principle:	contact between the sensor sensed liquid	
Response Time:	2 s after connecting the scanning contacts	
Measurement accuracy:	99.8 %	
Sensitivity:	in the range 0–170 kΩ	
Control		
Communication protocol:	RFIO	
Frequency:	866–922 MHz (for more information see p. 76)	
Repeater function:	no	
Signal transmission method:	unidirectionally addressed message	
Range:	in open space up to 160 m	
Other parameters		
Working temperature:	0 to +50 °C (Pay attention to the operating temperature of batteries)	
Storage temperature:	-20 to +60 °C	
Operation position:	capture contacts for flooding downwards	
Mounting:	loose	
Protection degree:	IP62	
Dimension:	Ø 89 x 23 mm	
Weight:	92 g	

Description

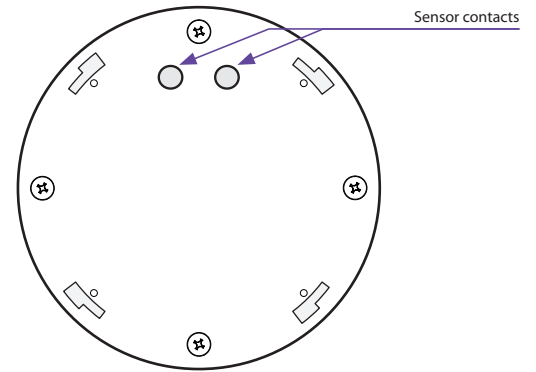

Function

When the scanning contact is connected, the detector sends the message and starts alarm.

Conductivity of liquids

Liquids suitable for detection		Inadmissible liquids
Type of liquid	Resistivity [Ωcm]*	
Drinking water	5–10 kΩ	Demineralised water
Well water	2–5 kΩ	Deionised water
River water	2–15 kΩ	Bourbon
Rain water	15–25 kΩ	Gasoline
Waste water	0.5–2 kΩ	Oil
Seawater	~0.03 kΩ	Liquid gases
Salt water	~2.2 kΩ	Paraffin
Natural/hard water	~5 kΩ	Ethylene glycol
Chlorinated water	~5 kΩ	Paints
Condensed water	~18 kΩ	High alcohol-content liquids
Milk	~1 kΩ	
Milk serum	~1 kΩ	
Fruit juices	~1 kΩ	
Vegetable Juices	~1 kΩ	
Broths	~1 kΩ	
Wine	~2.2 kΩ	
Beer	~2.2 kΩ	
Coffee	~2.2 kΩ	
Soap toam	~18 kΩ	

* Resistivity characterizes the resistive properties of materials which conduct electric current.



Technical parameters	RFSOU-1
Power supply:	2 x 1.5 AAA batteries
Battery Life:	Appr. 2 years, according to the number of controlled units
Setting the range of light levels	
Function ☾ (twilight switch)	
- Range 1:	1 to 10 lx
- Range 2:	10 to 100 lx
- Range 3:	100 to 1.000 lx
Function ☀ (light switch)	
- Range 1:	100 to 1 000 lx
- Range 2:	1 000 to 10 000 lx
- Range 3:	10 000 to 100 000 lx
Function setting:	rotary switch
The level of lighting gently:	0.1 to 1 x range
Fine adjustment of lighting levels:	potentiometer
The time delay t:	0/1 min./2 min.
Setting the delay time t:	rotary switch
Control	
Communication protocol:	RFIO
Frequency:	866–922 MHz (for more information see p. 76)
Repeater function:	no
Range:	in open space up to 160 m
Other data	
Working temperature:	-20 to +50 °C
Storage temperature:	-30 to +70 °C
Operating position:	sensor side down
Protection:	IP65
Degree of pollution:	2
Dimension:	72 x 62 x 34 mm
Weight:	104 g
Standards:	EN 60730-1, EN 300 220, EN 301 489 R&TTE Directive, Order. No 426/2000 Coll. (Directive 1999/EC)

- The twilight switch measures the light intensity and based on a set value, it sends the command to switch on the lights or pull the blinds up or down.
- It can be combined with multifunctional switching units and blind switches.
- Integrated sensor for measuring illumination, settable in 3 ranges 1-100,000 lx.
- Selection of function:
 - a) twilight switch – automatically switches on upon a decrease in ambient light intensity, switches off upon an increase (appropriate for garden lights, advertisements, public lighting, etc.).
 - b) light switch – automatically switches on upon an increase in ambient light intensity, switches off upon a decrease (appropriate for offices, restaurants, rooms, etc.).
- Settable delay up to 2 minutes to eliminate unwanted switching caused by surrounding influences.
- The twilight switch may control up to 32 units in the installation.
- The programming button on the regulator is used for:
 - a) setting a function with a switching or blind unit
 - b) ascertaining battery status
 - c) ascertaining signal quality between the unit and dimmer.
- Battery power (2x 1.5 V AAA batteries - included in supply) with battery life of around 2 years based on the number of controlled units.
- Range up to 160 m (in open space), if the signal is insufficient between the controller and unit, use the signal repeater RFRP-20 or protocol component RFIO2 that support this feature.
- Communication frequency with bidirectional protocol RFIO.
- The increased IP65 protection is suited to mounting on the wall or into the rural environment.

Device description

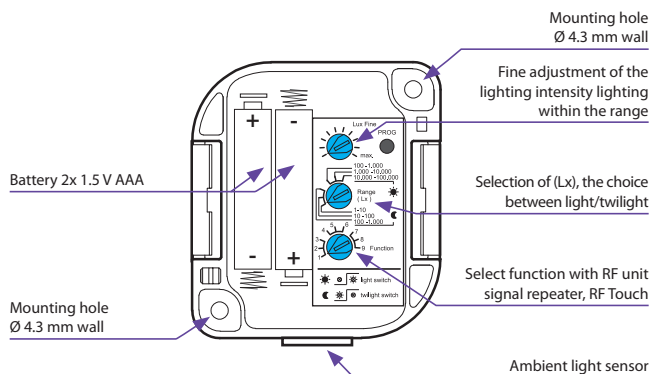



- The motion detector PIR is used to detect persons moving inside the building interior.
- Use:
 - in combination with a switching unit for automatic control of lighting or triggering an alarm.
 - by means of the Smart RF box, detection can be displayed on your smart phone in the form of a notification; alarms are stored in the history, which is visualized in the application iHC.
- Sensitivity settings of the PIR detector for eliminating unwanted triggering.
- Integrated lighting sensor, thanks to which you can set the detector's reaction time.
- Option of activation/deactivation of the LED indicator on the detector cover.
- Anti-tamper function: an alarm is triggered if there is an unauthorized interference to detector.
- Power supply: 2x 1.5 V AA batteries, the battery life is around 1 year.
- "Low Battery" Alerts by double LED flashing or on iHC App.
- The detectors are compatible with switching components marked with the RFIO2 communication protocol and the eLAN-RF system components.
- Communication frequency with bidirectional protocol RFIO.

Technical parameters		RFMD-100
Power supply:	2x 1.5 V AA batteries	
Battery life:	up to 1 year, according to the number of activations	
Drained battery indicator:	yes	
Control		
Communication protocol:	RFIO	
Frequency:	866-922 MHz (for more information see p. 76)	
Repeater function:	no	
Detection angle:	105°	
Detection distance:	max. 12 m	
Recommended working height:	max. 2.4 m	
Other data		
Working temperature:	-10 to +50 °C	
Protection:	IP20	
Colour:	white	
Dimension:	46 x 105 x 43 mm	
Weight:	57 g	

Detection field

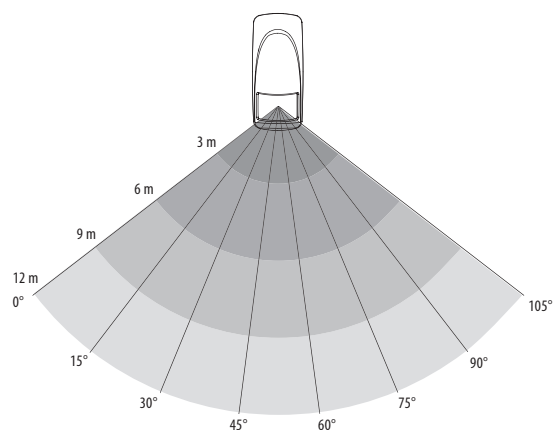



- The Window/Door detector is used to detect opening where activation occurs when the magnet and the sensor become separated.
- Use:
 - in combination with the switching unit for automatic light control (cellar, garage, etc.), or switching on a GSM gate
 - by means of the Smart RF box, detection can be displayed on your smart phone in the form of a notification; alarms are stored in the history, which is visualized in the application iHC.
- Anti-tamper function: an alarm is triggered if there is an unauthorized interference to detector.
- Power supply: 1x 3 V CR 2032 battery, the battery life is around 1 year, thanks to the ability to turn off the LED indicator it is possible to extend up to 3 years.
- "Low Battery" Alerts on Your iHC App.
- The detectors are compatible with switching components marked with the RFIO2 communication protocol and the eLAN-RF system components.
- Communication frequency with bidirectional protocol RFIO.

Technical parameters		RFWD-100
Power supply:	1x 3 V CR 2032 battery	
Drained battery indicator:	yes	
Control		
Communication protocol:	RFIO	
Frequency:	866–922 MHz (for more information see p. 76)	
Repeater function:	no	
Other data		
Working temperature:	-10 to +50 °C	
Protection:	IP20	
Colour:	white	
Dimension:	25 x 75 x 16 mm	
Magnet dimension:	15 x 75 x 14 mm	



Window/Door detector | RFWD-100



Flood detector | RFSF-100



RF Touch-B

RF Touch-W

Technical parameters	RF Touch-B	RF Touch-W
Display		
Type:	colour TFT LCD	
Resolution:	320 x 240 pixels/262,144 colours	
Side proportion:	3:4	
Visible surface:	52.5 x 70 mm	
Backlighting:	active (white LED)	
Touch area:	resistive 4-conductor	
Diagonal:	3.5"	
Control:	touch	
Power supply		
Supply voltage:	100–230 V AC	from the back 100–230 V AC, from the side 12 V DC
Input power:	max. 5 W	
Power supply terminals:	A1–A2	
Control		
Communication protocol:	RFIO2	
Frequency:	866–922 MHz (for more information see p. 76)	
Range:	in open space up to 100 m	
Min. distance RF Touch		
Actuator:	1 m	
Connection		
Connection:	no-screw push-in terminal box or jack	no-screw push-in terminal box or jack
	terminal box	connector
Cross-section of connecting wires:	max. 2.5 mm ² /1.5 mm ² with a hollow	
Other data		
Operating temperature:	0 to +50 °C	
Storage temperature:	- 20 to +70 °C	
Protection:	IP20	
Overvoltage category:	III.	
Contamination degree:	2	
Operating position:	any	
Installation:	an installation box	anywhere indoor
Dimensions:	94 x 94 x 36 mm	94 x 94 x 24 mm
Weight (plastic):	127 g	175 g
Related standards:	EN 60730-1	

- The Wireless touch unit RF Touch is a central controller for heating, switching electrical appliances and equipment, dimming lights, controlling blinds, etc.
- It transmits and receives commands from units and processes set programs for automatic control.
- Thanks to bidirectional communication, it visualizes the current status of individual units.
- Automatic control based on weekly program.
- It is possible to combine up to 40 units of iNELS RF Control + 30 Oasis detectors (you can gradually expand the installation from 1 unit).
- Power to the touch unit is in the range 100–230 V AC, (RF Touch/W also supplied via adapter 12 V DC included in the supply).
- Range up to 100 m (in open space), if the signal is insufficient between the RF Touch and unit, use the signal repeater RFRP-20 or protocol component RFIO2 that support this feature.
- Communication frequency with bidirectional protocol RFIO.

Power supply

RF Touch-B



RF Touch-W

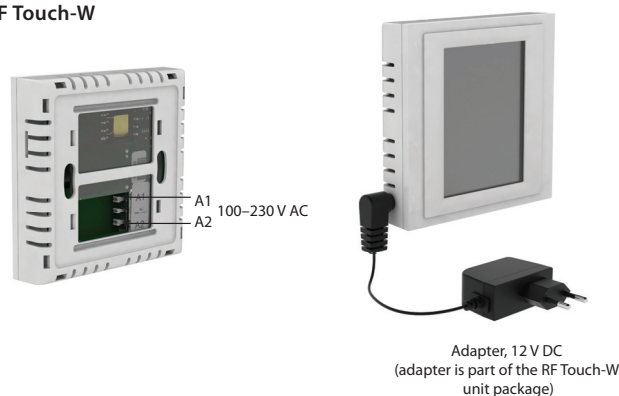

Adapter, 12 V DC
(adapter is part of the RF Touch-W unit package)

Colour combinations



black/white

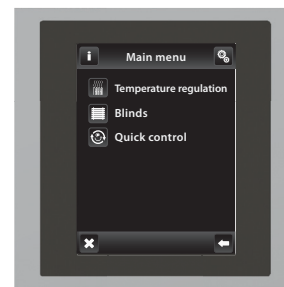

chrome/grey

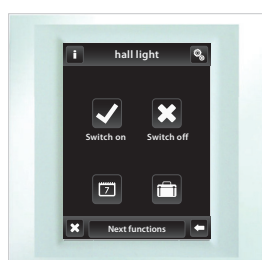

white/pearly



glass/grey



red/aluminum



aluminum/dark grey



titanium/ice

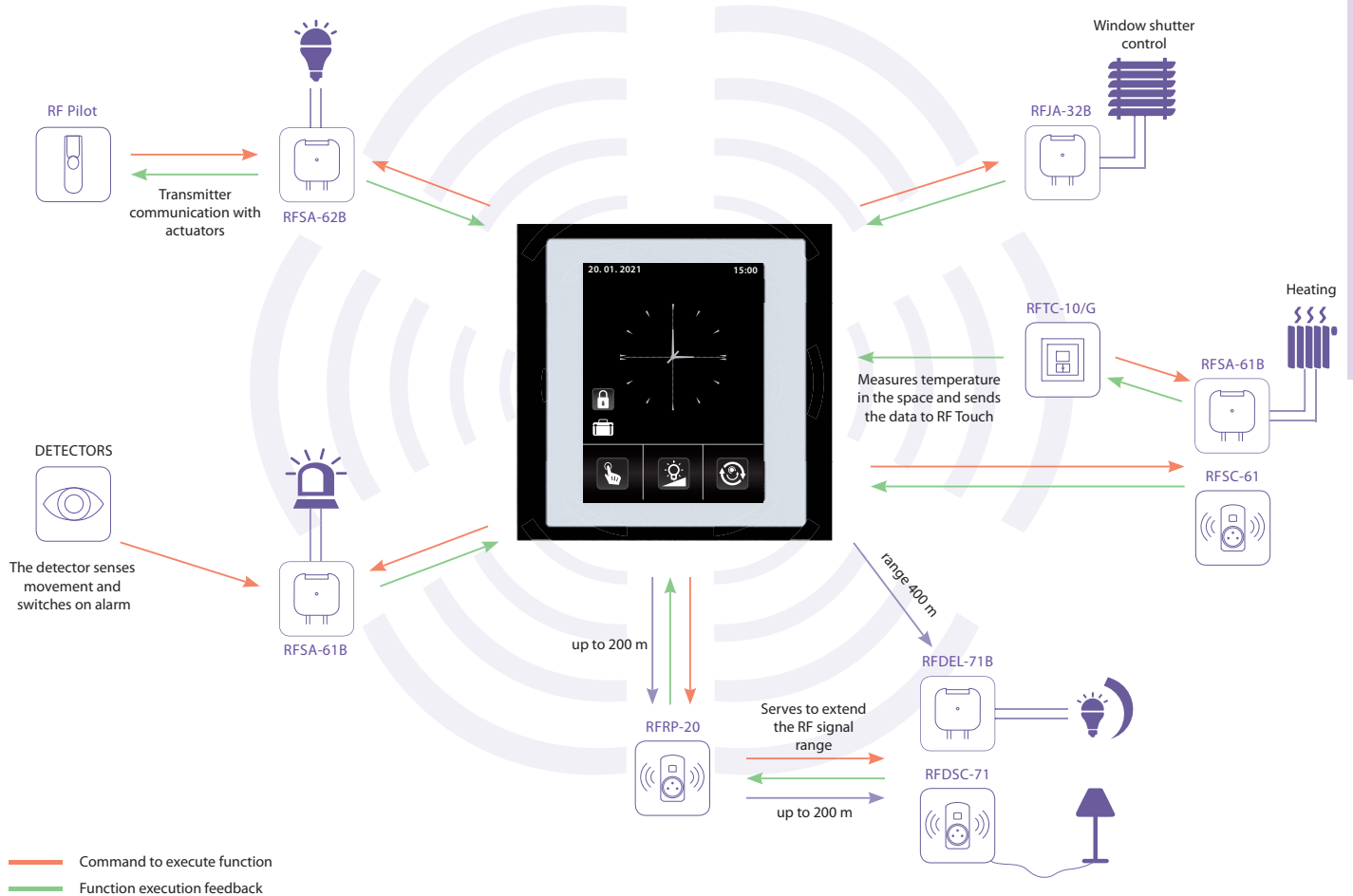

HEATING

- control of heating devices (boilers, thermo valve 0–10 V...)
- temperature regulation in the entire house or in individual rooms
- information about outdoor temperature (wireless temperature sensor) – terraces
- possibility to set your own heating program for the whole week
- holiday mode will interrupt the heating program when you are on holiday
- room temperature correction (during the heating program) is performed with a digital thermal regulator command

DIMMING

- the regulation of light intensity
- customizable names of individual dimmed circuits (such as “living room lights”)
- “sunrise/sunset” imitation - light gradually goes on or off during the preset period between 2 s and 30 min

DETECTORS

- RF Touch communicates with detectors - window, door, movement...
- possible to combine with switching actuators
- clear control over the entire house

SWITCHING

- this function serves to switch on/off lights, sockets, electrical appliances and devices
- intuitive control thanks to customized name options
- switch clock enabling you to switch appliances in real time, even during your absence (simulation of the presence of persons, etc.)
- switching actuator function selections: switch on/off, impulse relay, button, delayed ON/OFF (time of delay from 2 s to 60 min)

WINDOW SHUTTERS

- controlling window shutters, sunblinds, blinds, garage door, etc.
- window shutters are controlled separately or as a group
- setting an independent time schedule for pulling up/down
- the window shutter receivers are powered by either 230 V or 24 V DC (shutters between windows, etc.)

QUICK CONTROL

- serves to control group of actuators with a single touch
- possibility to set up scenes; on activation, for example, window shutters are pulled down and lights are adjusted to required intensity



- This signal repeater is used to extend the range between the controller and unit by up to 200 meters.
- It is designed to transmit a signal to up to 20 units.
- Indication:
 - green LED - supply voltage
 - red LED - active status (receiving and transmitting an RF signal)
- Programming is performed by a button.
- Communication frequency with bidirectional protocol RFIO.
- Thanks to the socket design, installation is simple by direct insertion into the existing socket, the throughsocket function remains unchanged.

Produced in 3 designs of sockets/plugs:

Technical parameters	RFRP-20/230V	RFRP-20/120V
Supply voltage:	230-250 V	120 V AC
Supply voltage frequency:	50-60 Hz	60 Hz
Apparent input:	6 VA	
Dissipated power:	0.7 W	
Control		
Communication protocol:	RFIO	
Frequency:	866-922 MHz (for more information see p. 76)	
Range:	in open space up to 200 m	
Minimum control distance:	20 mm	
Programming:	button - green LED/red LED	
Other data		
Operating temperature:	-20 to +55 °C	
Storage temperature:	-30 to +70 °C	
Mounting:	plug into a socket	
Protection:	IP20 Device	
Dimensions:	60 x 120 x 80 mm	
Weight:	225 g	
Related standards:	EN 607 30-1 ED.2	



French



Schuko

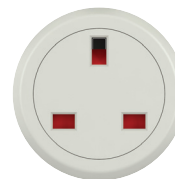

British

Signal transmission and extension for up to 20 components.

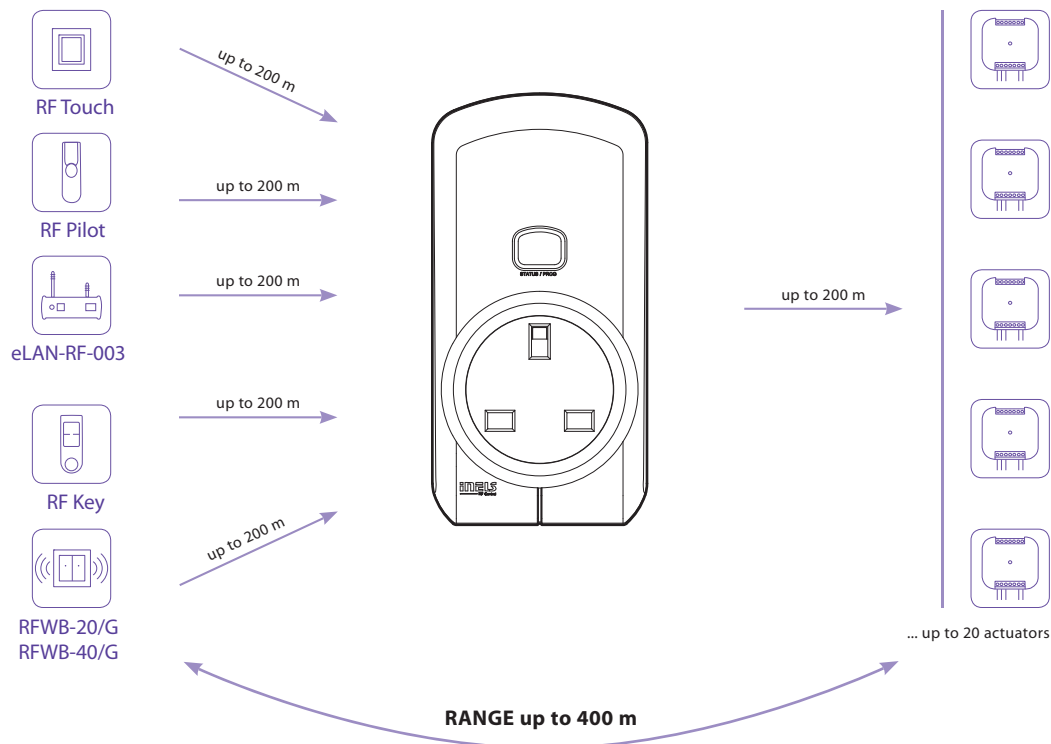



Technical parameters	eLAN-RF-103	eLAN-RF-Wi-103
Interface RF Control		
Communication protocol:	RFIO2	
Broadcasting frequency:	866–922 MHz (for more information see p. 76)	
Signal transfer method:	two-way addressed message	
Output for antenna:	SMA connector*	
Antenna RF:	AN-I 1 dB	
Indications RF communications:	1x green RF LED	
Range:	in open space up to 100 m	
Interface Ethernet		
ETH operating status indicator:	green LED	
ETH communication indicator:	yellow LED	
Communications interface:	100 Mbps (RJ45)	
Preset IP address:	DHCP	
Interface Wi-Fi		
Standard:	x	IEEE 802.11 b/g/n/2.4 GHz
Wi-Fi Security:	x	WEP, WPA-PSK, WPA2-PSK
Frequency range Wi-Fi:	x	R-SMA connector*
Antenna Wi-Fi:	x	WiFi 2.4 GHz 1 dB
Indications Wi-Fi communication:	x	1x green LED Wi-Fi
Range:	x	up to 20 m
Wi-Fi network mode:	x	SOFT-AP/Client
Power supply		
Supply voltage/current:	5 V DC/0.5 A	5 V DC/1 A
Power source:	110–230 V AC/5 V DC–2 A (connector USB-C)	
Button RESET		
- short press:	restart the device	
- press > 5 s:	reset network settings	
- press > 10 s:	reset to factory settings	
Indication LED STATUS		
- green:	normal mode	
- red:	error condition	
- orange:	initialization/start	
Other data		
Operating temperature:	-20 to +50 °C	
Storage temperature:	-25 to +70 °C	
Protection:	IP20	
Contamination degree:	2	
Working position:	any	
Dimensions:	90 x 52 x 65 mm	
Weight:	136 g	146 g

* Max Tightening Torque for antenna connector is 0.56 Nm.

- The Smart RF Box is a gateway between iNELS RF elements and applications for smartphones, tablets, watches, televisions, voice assistants (Google Home & Alexa) and other third-party devices.
- It is produced in two versions:
 - a) eLAN-RF-103: LAN communication
 - b) eLAN-RF-Wi-103: LAN communication with WiFi in AP (Access Point) mode with direct connection of the smartphone to eLAN-RF-Wi-103 or in Client mode (connection to the home WiFi network by connecting the smartphone via home wireless router).
- It communicates from up to 70 iNELS RF elements, processes set programs for automatic control.
- Thanks to two-way communication, it displays the current status of individual elements.
- Powered by 5 V DC/2 A adapter, USB-C connector (included).
- Configuration is done via the iHC application.
- The package includes an internal antenna AN-I, in case the Smart RF box is located in a metal switchboard, you can use the external antenna AN-E for better signal reception, see accessories on page 75. For the eLAN-RF-Wi-103 version, a WiFi antenna is included in the package.

Device description

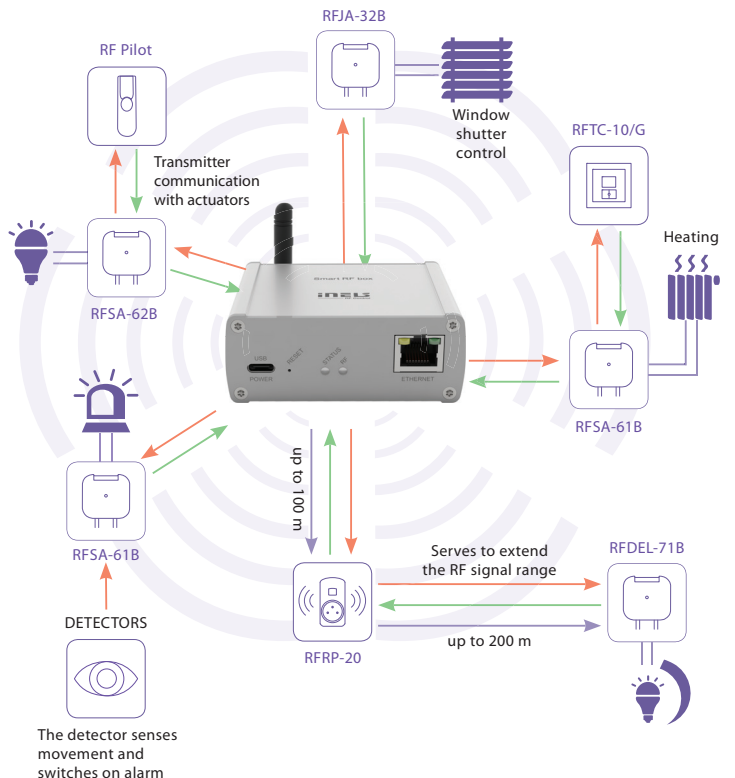
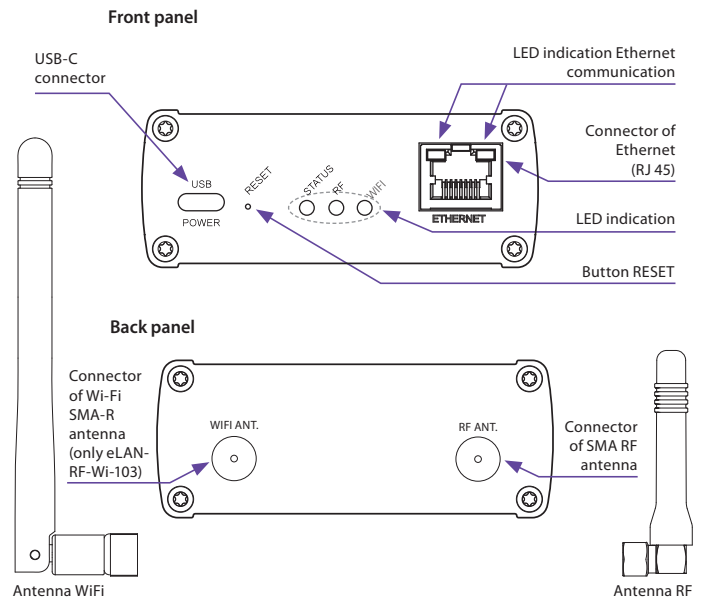

— Command to execute function
 — Function execution feedback

Hotel Retrofit (HRESK)

Cost savings, increased comfort

HRESK



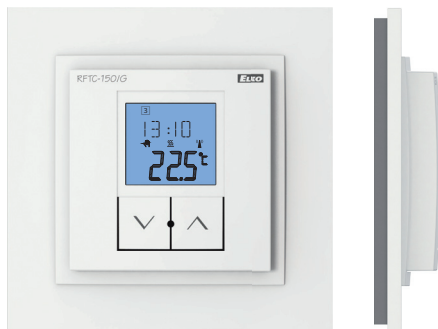

- The wireless controller RFTC-150/G measures the room temperature by internal sensor. On the basis of a set program it sends commands to the switching component RFS-166M Switching fan coil.
- It is possible to set automatic or manual mode.
- Range of measured temperature 0 to 55 °C.
- The backlit LCD display displays the current and set temperature, status (ON/OFF), battery status, day of the week, current time, etc.
- Battery power (2x 1.5 V AAA batteries - included in supply) with battery life of around 1 year based on frequency of use.
- The flat rear side of the device enables its placement anywhere in the room.
- Components support communication with RF detectors.
- Range up to 100 m (in open space), if the signal is insufficient between the controller and unit, use the signal repeater RFRP-20 or protocol component RFIO2 that support this feature.
- Communication frequency with bidirectional protocol RFIO.
- Colour combination of temperature unit in design of frames LOGUS⁹⁰ (plastic, glass, wood, metal, stone).

Technical parameters		RFTC-150/G
Supply voltage:	2x 1.5 V AAA batteries	
Battery life:	up to 1 year	
Temperature correction:	2 buttons V/Λ	
Temperature offset:	± 5 °C	
Display:	LCD, characters	
Backlighting:	active 10 s after pressing	
Transmission indication/function:	symbols	
Temperature measurement input:	1x internal sensor	
Temp. measurement range and accuracy:	0 to + 55 °C ; 0.3 °C of the range	
Control		
Communication protocol:	RFIO	
Frequency:	866–922 MHz (for more information see p. 76)	
Repeater function:	no	
Signal transmission method:	bidirectionally addressed message	
Range:	in open space up to 100 m	
Minimum control distance:	20 mm	
Other data		
Max. number of controlling actuators RFS-166M:	1	
Program:	weekly	
Operating temperature:	0 to +55 °C	
Operating position:	on the wall	
Mounting:	by gluing/screwing	
Protection:	IP30	
Contamination degree:	2	
Dimensions		
- plastic:	85 x 85 x 20 mm	
- metal, glass, wood, granite:	94 x 94 x 20 mm	
Weight:	66 g (without batteries)	
Related standards:	EN 60669, EN 300 220, EN 301 489 directive RTTE Directive, Order. No 426/2000 Coll. (Directive 1999/EC)	

Connection

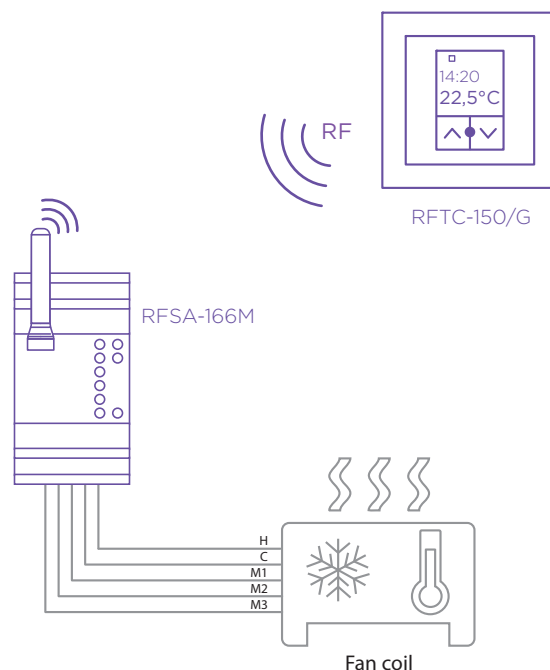



Technical parameters RFSAI-161B/230V RFSAI-161B/120V

Supply voltage:	230 V AC	120 V AC
Supply voltage frequency:	50–60 Hz	60 Hz
Apparent power:	9 VA	9 VA
Dissipated power:	0.7 W	
Supply voltage tolerance:	+10 %; -15 %	

Output

Number of contacts:	1x switching (AgSnO ₂)
Rated current:	12 A/AC1
Switching power:	3000 VA/AC1, 288 W/DC
Peak current:	30 A, max. 4 s at 10%
Switching voltage:	250 V AC1/24 V DC
Min. switching power DC:	100 mA/10 V
Insulation voltage between outputs and internal circuits:	basic insulation (Cat. III surges by EN 60664-1)
Isolation voltage open contact:	1 kV
Mechanical service life:	3x10 ⁷
Electrical service life (AC1):	5x10 ⁴
Indication of relay switch:	red LED

Control

Communication protocol:	RFIO2
Frequency:	866–922 MHz (for more information see p. 76)
Repeater button:	yes
Manual control:	button PROG (ON/OFF)
External button:	cable length max. 12 m $\triangle_{\frac{1}{2}}$ *
Range:	in open space up to 160 m

Other data

Open contact voltage external switch:	3 V
Resistor for the management of external switch:	<1 k Ω
Resist. of connection for open contact:	>10 k Ω
Galvanic isolation of input:	no
Operating temperature:	-15 to +50 °C
Storage temperature:	-30 to +70 °C
Working position:	any
Mounting:	free at lead-in wires
Protection:	IP30
Overvoltage category:	III.
Contamination degree:	2
Terminals:	0.5–1 mm ²
Terminals (CY wire, Cross-section):	2x 0.75 mm ² , 2x 2.5 mm ²
Terminal length:	90 mm
Dimensions:	49 x 49 x 21 mm
Weight:	50 g

* We recommend using a twisted pair cable for this distance.

$\triangle_{\frac{1}{2}}$ Control button input is at the supply voltage potential.

- Switch component with one output channel which is used in combination with detectors for automatic lighting control.
- RFSAI-161B has a pre-set control algorithm (scene) adapted to the requirements of hotel room control, see wiring.
- Each RFSAI-161B can be programmed with 1x RFMD-100, 1x RFWD-100 and 1x wireless controller (RFBW-40/G or RF KEY).
- The terminals on the component give you the opportunity to connect a wired detector or an existing key installation.
- It enables connection of the switched load up to 1x 12 A (3000 VA).
- The programming button on the unit is also used for manual control of the output.
- Range up to 160 m (in open space), if the signal is insufficient between the controller and unit, use the signal repeater RFRP-20 or protocol component RFIO2 that support this feature.
- Communication frequency with bidirectional protocol RFIO2.

Device description

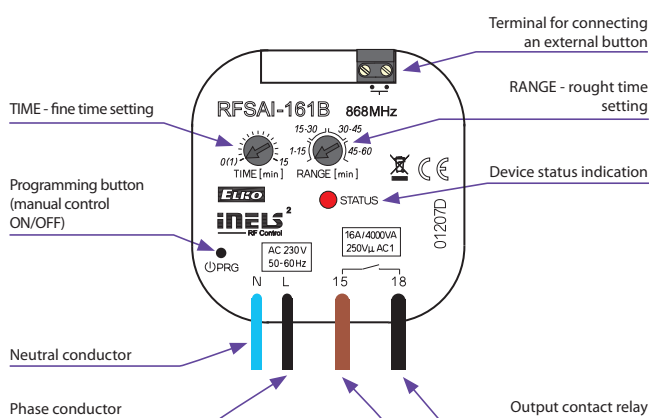

Compatible wireless detectors:
 Movement: RFMD-100
 Door/Window: RFWD-100

Connection

RFSAI-161B/230V
 RFSAI-161B/120V

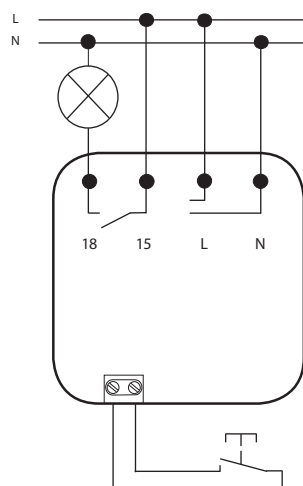

Example

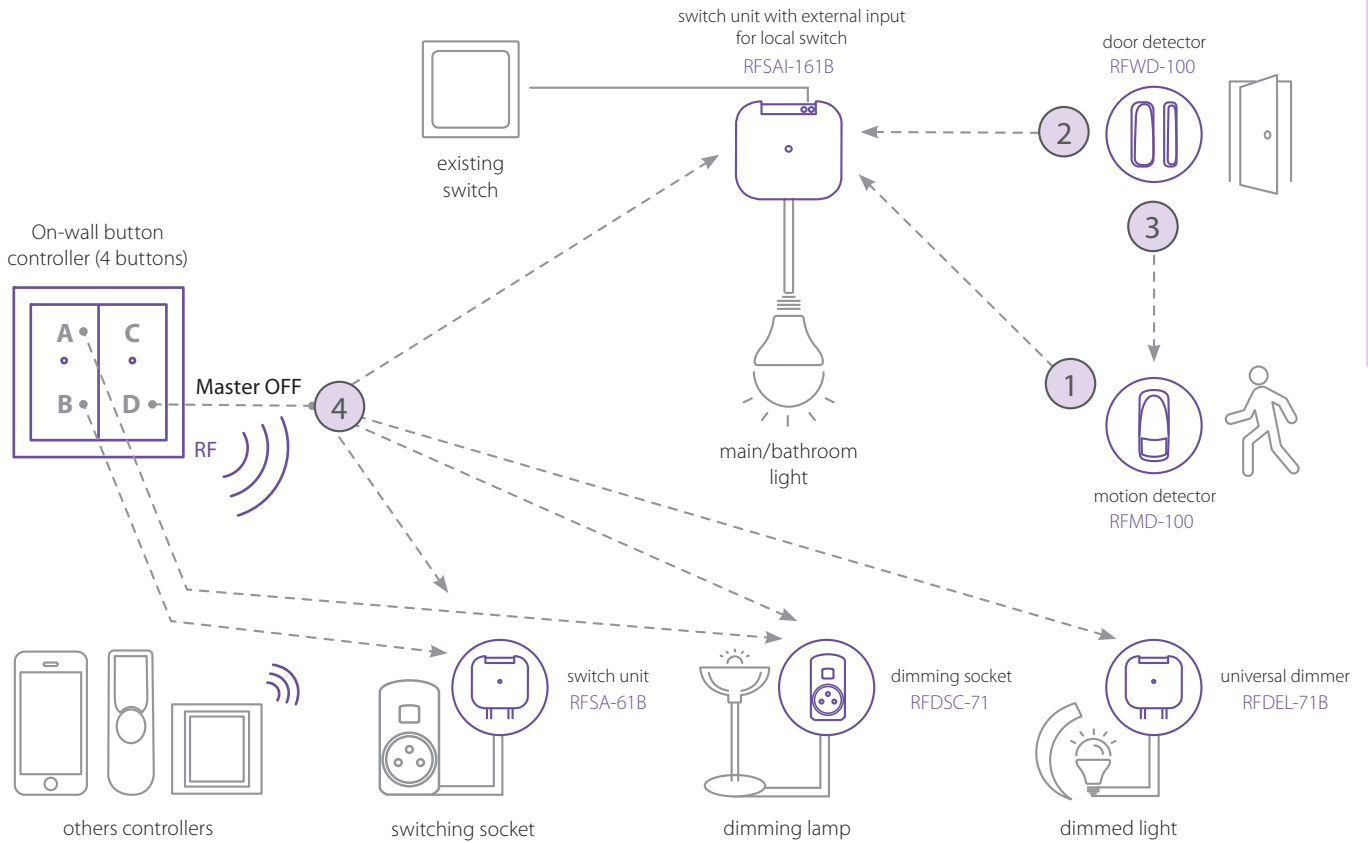

Function

- 1 When RFMD-100 motion detector captures the movement of the guest, the light ON command is sent.
- 2 The functionality of RFWD-100 door detector is delayed OFF= after the guest (or cleaner) close the door than the timer starts running (which you can set) and the light will turn OFF.
- 3 If there is movement the command from RFWD-100 door detector (delay off) will be cancelled by the motion detector RFMD-100 command.
- 4 Pressing the button at position D of RFWB-40 On-wall button controller sends an OFF command to all components that are controlled from that button while blocking the response to RFMD-100 motion detector.
- 5 You are able to control other units with other channels (A, B, C) on RFWB-40 On-wall button controller.
- 6 When guest wakes up and presses any RFWB-40 button, then pressing on button makes all units working again after previous pressing button on position D and it also re-enable RFMD-100 motion detector primary function.

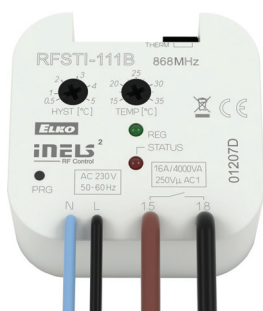

Technical parameters RFSTI-111B/230V RFSTI-111B/120V

Supply voltage:	230 V AC	120 V AC
Supply voltage frequency:	50–60 Hz	60 Hz
Apparent input:	9 VA/cos φ= 0.1	9 VA/cos φ= 0.1.
Dissipated power:	0.7 W	
Supply voltage tolerance:	+10 %; -15 %	
Temperature measurement input:	1x external TZ/TC temperature sensor input \triangleleft	
Temp. measurement range and accuracy:	+15 to +35 °C; 0.5 °C of the range	

Output

Number of contacts:	1x switching (AgSnO ²)
Rated current:	12 A/AC1
Switching power:	3000 VA/AC1, 288 W/DC
Peak current:	30 A/max. 4 s at 10%
Switching voltage:	250 V AC1/24 V DC
Min. switching power:	100 mA/10 V
Insulation voltage between relay outputs and internal circuits:	basic insulation (Cat. III surges by EN 60664-1)
Isolates. voltage open relay contact:	1 kV
Mechanical service life:	3x10 ⁷
Electrical service life (AC1):	5x10 ⁴

Control

Communication protocol:	RFIO2
Frequency:	866–922 MHz (for more information see p. 76)
Repeater function:	yes
Range:	in open space up to 160 m

Other data

Operating temperature:	-15 to +50 °C
Storage temperature:	-30 to +70 °C
Indication of relay switch:	red LED
Indication regulation:	green LED
Operating position:	any
Mounting:	free at lead-in wires
Protection:	IP30
Overvoltage category:	III.
Contamination degree:	2
Outlets (CY wire, cross-section, length):	2 x 0.75 mm ² , 2 x 2.5 mm ² , 90 mm
Dimensions:	49 x 49 x 21 mm
Weight:	50 g

\triangleleft Temperature sensor input is at the supply voltage potential.

- The component measures temperature in the range of 15 to 35 °C with external sensor and on the basis of the set temperature switches air conditioning.
- It is particularly suitable for hotel rooms.
- With the Window/Door sensor programmed, when the window/door is opened, the device relay contact is automatically disconnected, there by saving unnecessary energy consumed for cooling when the window/door is open.
- It enables connection of the switched load up to 12 A (3000 VA).
- Up to 4 RFDW-100 detectors can be connected to one RFSTI-111B device.
- Range up to 160 m (in open space), if the signal is insufficient between the controller and unit, use the signal repeater RFRP-20 or protocol component RFIO2 that support this feature.
- Communication frequency with protocol RFIO2.
- The BOX design lets you mount it right in an installation box, a ceiling or controlled appliance cover.
- External sensor TC (-20 to +80 °C) or TZ (-40 to +125 °C) for length of 3 m, 6 m, 12 m. For more information see „Accessories“ on page 43.

Device description

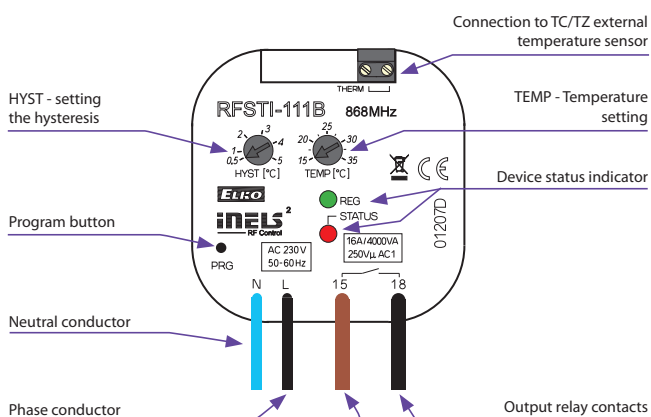

Function

The external sensor senses the temperature of the room, turns the air conditioner on and off according to the set temperature. Responds to commands from the detector - when you open the window, turn off air conditioning.

Connection

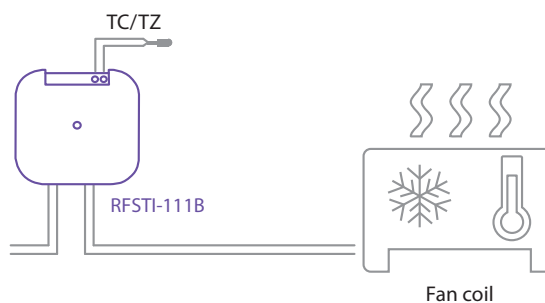



Technical parameters		RFS-166M/230V
Supply voltage:		110–230 V AC
Supply voltage frequency:		50–60 Hz
Apparent input:		min. 2 VA/max. 5 VA
Dissipated power:		min. 0.5W/max. 2.5W
Supply voltage tolerance:		+10%/-25 %
Output		
Number of contacts:		3x changeover (AgSnO ₂); 3x switching (AgSnO ₂)
Rated current:		8 A/AC1
Switching power:		2000 VA/AC1
Peak current:		10 A/<3 s
Switching voltage:		250 V AC1
Max. DC switching power:		500 mW
Mechanical service life:		1x10 ⁷
Electrical service life (AC1):		1x10 ⁵
Control		
Wireless:		on output RE6 up to 25-channels/buttons
Communication protocol:		RFIO2
Frequency:		866–922 MHz (for more information see p. 76)
Repeater button:		yes
Manual control:		MAN button
Range:		in open space up to 100 m
RF antenna:		AN-I included (SMA connector)*
Other data		
Operating temperature:		-15 °C to +50 °C
Operating position:		any
Mounting:		DIN rail EN 60715
Protection:		IP20 from the front panel
Overvoltage category:		III.
Contamination degree:		2
Connecting conductor cross-section (mm ²):		max. 1x 2.5, max. 2x 1.5/ with a hollow max. 1x 2.5
Dimensions:		90 x 52 x 65 mm
Weight:		264 g
Related standards:		EN 60669, EN 300 220, EN 301 489 R&TTE Directive, Order. No 426/2000 Coll. (Directive 1999/EC)

- Thanks to the 6-channels design of the switching component it can control the heating/cooling mode and with 3 speeds, the AUX output channel can be used to control appliances, sockets or lights.
- The RFS-166M wireless switching component can be combined with the RFTC-150/G.
- Up to 25 detectors RFD-100 can be assigned to the switching component.
- The RFD-100 can be assigned to the RFS-166M using the PRG button.
- Output Channel AUX:
 - up to 25-channels can be controlled,
 - can be combined with detectors, controllers or system components of iNELS RF Control,
 - function: button, pulse relay and delayed start or return time functions with 2 s – 60 min time setting. Function description can be found on page 78,
 - memory status is retained in the event of a power failure,
 - the AUX programming button on the component also serves as manual control of the AUX output.
- The package includes an internal antenna AN-I, in case of locating the element in a metal switchboard, you can use the external antenna AN-E for better signal reception, see accessories on page 75.
- Range up to 100 m (in open space), if the signal is insufficient, use the signal repeater RFRP-20 or protocol component RFIO2 that support this feature.
- Communication frequency with bidirectional protocol RFIO2.

Connection for fancoil control

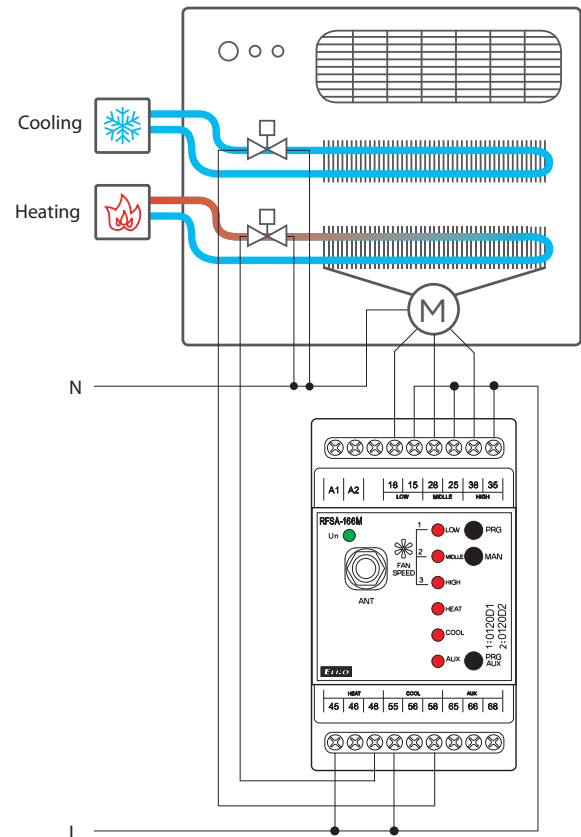

* Max Tightening Torque for antenna connector is 0.56 Nm.

Smartphones



- Control application for smartphones and tablets with Android and iPhone operating systems - iHC-AiO. It allows you to easily control your house.
- The user-friendly and intuitive application environment offers central control from one place.
- The application enables control of the complete iNELS RF and BUS solution via the RF Smart box, Connection server, Central unit and other supported third-party devices that are connected to the home Internet network.
- The application allows free remote control.
- iHC-AiO features:
 - unification of all iNELS devices under one application. Specifically, eLAN RF 003, eLAN RF 103, eLAN IR, CU3, CS and LARA
 - within BUS it is now possible to configure rooms without the need for a public server or CS
 - user management - in the application it will be possible to set rights for all users who will use one system
 - automation - creation of conditions within RF, BUS systems or in both systems
 - low battery notification, alarms, actuator status
 - history of states of individual actors
 - display of all added devices in a clear menu and the possibility of configuring your own dashboard.

Smart TV



- Device control via Smart TV is possible not only in the wireless installation of iNELS RF Control using the smart box eLAN-RF, but also in the case of wired option iNELS BUS using the Connection server. The iHC-SMTV app is free to download from the app store on your Smart TV.
- The control of app works with a classic TV remote control.
- Every Smart TV that has been manufactured since 2015 and supports OS Tizen is compatible.
- Functionality:
 - ON/OFF switching, with the possibility of time schedules
 - dimming ON/OFF, smooth brightening/dimming, color change
 - scenes
 - heating (temperature correction, heating mode change, cooling/heating mode)
 - cameras (image, or live stream if supported by web browser on Smart TV).
- iHC-SMTV (Smart TV App) is free and is not licensed in any way.
- Here you will find a link to the application:



Smart watch Samsung GEAR S2 / S3



TIZEN[®] iHC-WTRF

- Applications to control appliances via smart watches Samsung Gear S2/S3.
- Smart watches are associated with the controlled appliances through RF smart box eLAN-RF.
- Functionality:
 - switching appliances, sockets
 - automatic timing
 - dimming the lights, adjust the colour
 - control garage doors, gates, gates and shutters
 - features scenes for group commands.
- Intuitive and easy to control in many combinations, touching the display and moving wheels on Samsung Gear S2/S3.
- The setting is done by applying iNELS Home Control iHC-MAIRF directly or via a web interface RF smart box eLAN-RF.
- It is not necessary to carry a smart phone to control, the watch functions independently.

Amazon Alexa



- With Alexa Artificial Intelligence, you can simplify your daily life by setting an alarm, notifications, creating new items, or reminders in your calendar.
- The voice assistant can answer questions and control individual devices and smart homes.
- It is available on mobile phones, TVs, smart speakers and other devices.
- The voice assistant is designed to comfortably control the RF Control wiring by voice using your mobile phone or smart speaker.
- As a complement to RF Control, iNELS Smart Home Solution blends in with every modern home.
- Here you will find a link to the manual:



Google Home



Google HOME

- Google Home can become a member of your smart home family.
- It communicates with the smart eLAN-RF box via the Cloud connection.
- This allows you to control, for example, the temperature setting or the light intensity by voice.
- The voice assistant is designed to conveniently control the RF Controlled electro-installations by voice using your mobile phone or smart speaker.
- As a complement to RF Control, iNELS Smart Home Solution blends in with every modern home.
- Here you will find a link to the manual:

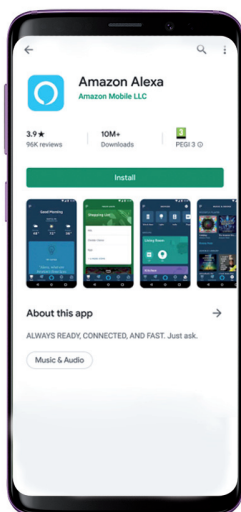

Register to the Cloud via email and set a password.

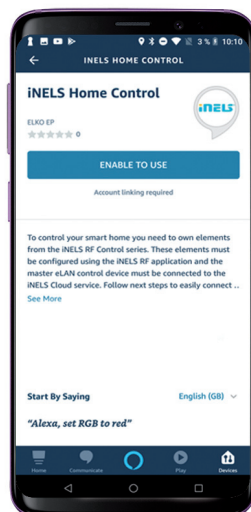

Preview the Amazon Alexa app on Google Play.

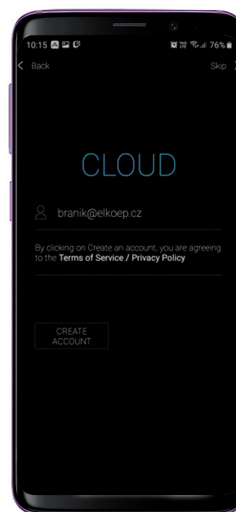

Preview the Amazon Alexa app on Google Play.

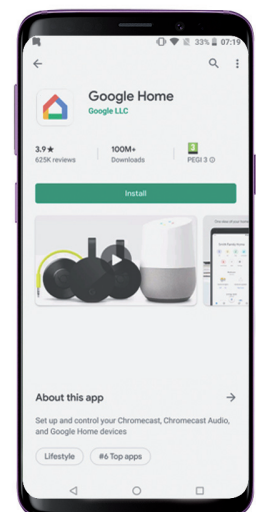

Setting up products in iNELS Home Control.

Application iHC-MAIRF-Cloud/iHC-MIIRF-Cloud:

- Designed for iOS 10+ and Android 5.0+.
- Optimized for devices with 800x480 screen resolution.
- The language of the application changes automatically according to the language set in Android/iOS.
- You can create a cloud account using the Setup Wizard or the login button in the main menu. The recommended minimum speed for connecting the eLAN-RF to the Cloud should be in the order of megabytes per second (3G - 1Mbit/s and higher).

AN-I | Internal antenna



AN-I antenna measurement graph

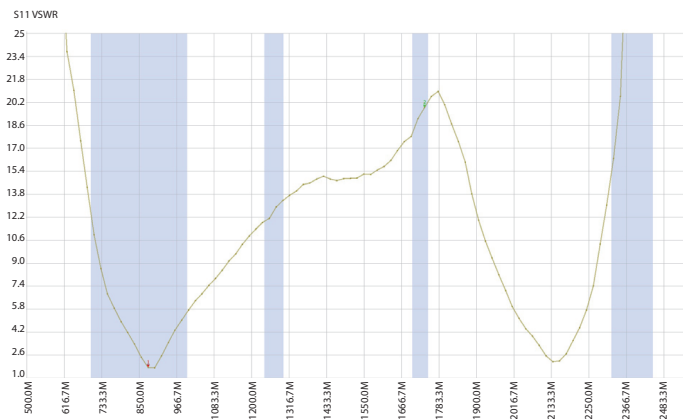

- The internal antenna is included in the standard package.

Technical parameters

AN-I

Polarization:	vertical
Gain:	2.1 dBi
Dimensions:	17 x 44 x 8.5 mm
Impedance:	50 Ω
Colour:	black

The rod antenna with SMA connector is supplied as standard with the product.

Extension cable for external antenna



10 m

Technical parameters

Connector Type:	SMA (male/female)
Colour:	white
Cable Length:	10 m

Measured range between controllers and RFSA-66M

	RFGB	RFWB	RF KEY
AN-I	305 m	290 m	190 m
AN-E	300 m	290 m	200 m
AN-E3	275 m	260 m	180 m

The range is measured with direct visibility between the RFGB-x, RFWB-x, RF KEY and RFSA-66M actuators.

Connecting the antenna extension cable does not affect the range.

AN-E1 | External antenna



AN-E antenna measurement graph

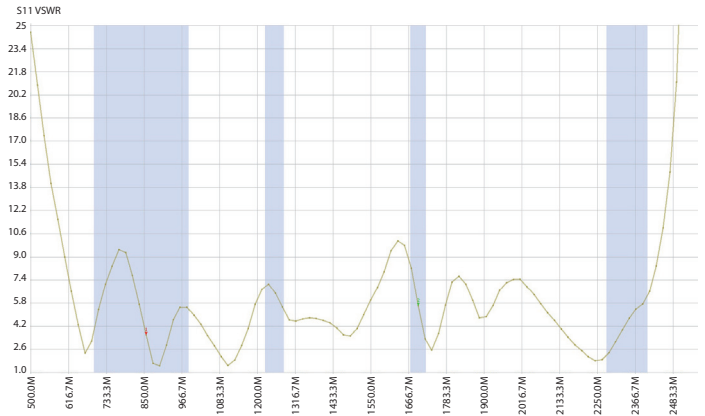

Technical parameters	AN-E1
Mounting:	Magnetic Mount
Cable Length:	3 m
Polarization:	vertical
Gain:	5 dBi
Impedance:	50 Ω
Colour:	black
Dimensions:	Ø 30 x 280 mm

AN-E3 | External antenna



AN-E3 antenna measurement graph

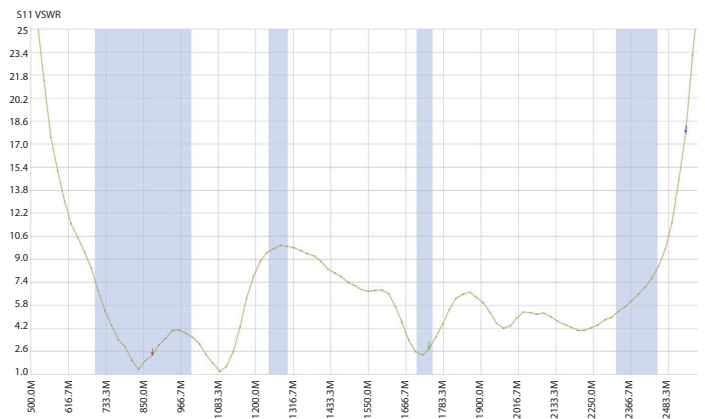

Technical parameters	AN-E3
Cable Length:	3 m
Polarization:	vertical
Gain:	3 dBi
Impedance:	50 Ω
Colour:	black
Dimensions:	Ø 50 x 88 mm

- The external antenna is intended for outdoor use.

RFAF/USB | Service Key



- The RFAF/USB Service Key (in conjunction with the RF_analyzer) is designed for iNELS RF Control system partners and serves for:
 - Setting the repeater (signal amplifier) through the iNELS RF Control elements labeled as RFIO2. This option allows you to communicate over longer distances (in the order of 50 m) via existing iNELS RF Control elements in the installation (eliminating the use of the RFRP-20 repeater).
 - upgrade of firmware in the iNELS RF Control elements (labeled RFIO2), in the case of new firmware versions that improve the functionality of the elements on which we are constantly working.
 - The RF Network Analyzer will reliably analyze the communication between the controller (where you plan to place it) and the component in the installation. Indicates signal strength/quality as well as possible frequencies that can interfere with communication.
 - SW RF analyzer can be found at inels.com/partners in section SW/FW RF Control

Technical parameters	RFAF/USB
Power:	max. 1 W
Interface:	USB 1.1 and higher, plug „A“
Range:	100 m
Min. distance of RF Touch-Actuator:	1 m
Communication protocol:	RFIO2
Frequency:	866–922 MHz (for more information see p. 76)
Power supply indication:	green LED
RF communication indication:	red LED
Other data	
Operating temperature:	0 to +55 °C
Storage temperature:	- 20 to +70 °C
Protection:	IP30
Contamination degree:	2
Work space:	any
Installation:	any
Dimensions:	22 x 85 x 15 mm
Weight:	20 g
Related standards:	EN 60950-1

Supported video cameras



HIK VISION



D-link



Axis

- Cameras integrated in iHC-MIIRF and iHC-MAIRF applications:
 - Axis cameras with PTZ control support.
 - HIK VISION cameras with PTZ control support.
 - D-Link cameras.
 - Other cameras supporting RTSP and MJPEG streams.
- IHC-SMTV supports streaming cameras in JPEG format.

Supported intercoms



- The iHC-MAIRF/iHC-MIIRF applications are integrated as client accounts for the SIP server on the Connection Server (Asterisk) and the SIP server on the Dahua speaker.
- Using CS, it is possible to freely connect applications with LARA Intercom, 2N and HIK VISION voices.



Basic sets

RFSET-SW2-Z1



1x Wireless switch unit
RFS-A-11B

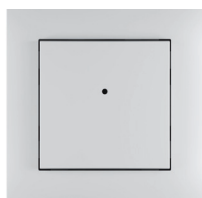

1x Wireless wall controller
RFWB-20/G - white

EAN: 8595188138901

RFSET-SK-Z1



1x Wireless switch unit
RFS-A-11B



1x Keychain
RF Key/B - black

EAN: 8595188138741

Multifunction sets

RFSET-SW-F1



1x Wireless switch unit
RFS-A-61B

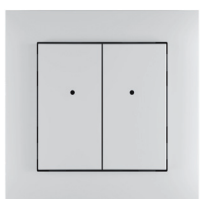

1x Wireless wall controller
RFWB-40/G - white

EAN: 8595188138772

RFSET-SK-F1



1x Wireless switch unit
RFS-A-61B



1x Keychain
RF Key/B - black

EAN: 8595188138789

RFSET-SMK-F1



1x Wireless switch unit RFS-A-61M
with external antenna A-NI



1x Keychain
RF Key/B - black

EAN: 8595188138895

Single function - RFSA-11B

Function button ON/OFF

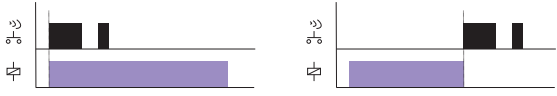

The output contact closes by pressing one button position, and opens by pressing the other button position.

Multi function - RFSA-61B, RFSA-62B, RFSA-61M, RFSA-66M, RFSAI-61B, RFSAI-62B, RFSC-61, RFUS-61

Function 1 - button

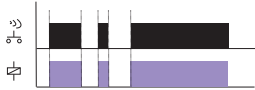

The output contact will be closed by pressing the button and opened by releasing the button.

Function 2 - switch on



The output contact will be closed by pressing the button.

Function 3 - switch off



The output contact will be opened by pressing the button.

Function 4 - impulse relay

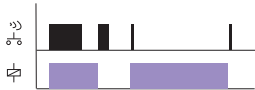

The output contact will be switched to the opposite position by each press of the button. If the contact was closed, it will be opened and vice versa.

Function 5 - delayed off

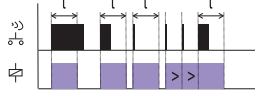

The output contact will be closed by pressing the button and opened after the set time interval has elapsed.
t = 2 s to 60 min.

Function 6 - delayed on

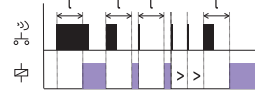

The output contact will be opened by pressing the button and closed after the set time interval has elapsed.
t = 2 s to 60 min.

Loadability products

RFJA-32B; RFSA-62B; RFSAI-62B; RFSA-66M

Load type	$\cos \phi \geq 0.95$								
	AC1	AC2	AC3	AC5a without compensation	AC5a with compensation	AC5b	AC6a	AC7b	AC12
Contact material AgSnO ₂ Contact 8 A	250 V/8 A	250 V/5 A	250 V/4 A	x	x	250 W	250 V/4 A	250 V/1 A	250 V/1 A
Load type									
	AC13	AC14	AC15	DC1	DC3	DC5	DC12	DC13	DC14
Contact material AgSnO ₂ Contact 8 A	x	250 V/4 A	250 V/3 A	30 V/8 A	24 V/3 A	30 V/2 A	30 V/8 A	30 V/2 A	x

RFUS-61

Load type	$\cos \phi \geq 0.95$								
	AC1	AC2	AC3	AC5a without compensation	AC5a with compensation	AC5b	AC6a	AC7b	AC12
Contact material AgSnO ₂ Contact 14 A	250 V/12 A	250 V/5 A	250 V/3 A	230 V/3 A (690 VA)	230 V/3 A (690 VA) up to max input C=14uF	1000 W	x	250 V/3 A	x
Load type									
	AC13	AC14	AC15	DC1	DC3	DC5	DC12	DC13	DC14
Contact material AgSnO ₂ Contact 14 A	x	250 V/6 A	250 V/6 A	24 V/10 A	24 V/3 A	24 V/2 A	24 V/6 A	24 V/2 A	x

RFSA-11B; RFSA-61B; RFSA-61M; RFSC-61; RFSTI-11B; RFDAC-71B

Load type	$\cos \phi \geq 0.95$								
	AC1	AC2	AC3	AC5a without compensation	AC5a with compensation	AC5b	AC6a	AC7b	AC12
Contact material AgSnO ₂ Contact 16 A	250 V/16 A	250 V/5 A	250 V/3 A	230 V/3 A (690 VA)	230 V/3 A (690 VA) up to max input C=14uF	1000 W	x	250 V/3 A	250 V/10 A
Load type									
	AC13	AC14	AC15	DC1	DC3	DC5	DC12	DC13	DC14
Contact material AgSnO ₂ Contact 16 A	x	250 V/6 A	250 V/6 A	24 V/10 A	24 V/3 A	24 V/2 A	24 V/6 A	24 V/2 A	x

Multi function RFDA-73M/RGB, RFDEL-71B, RFDEL-71M, RFDSC-71, RFDAC-71B, RFDW-71

Light scene function 1

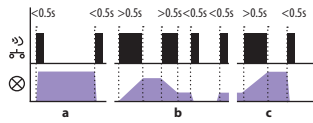

- a) By pressing the programmed button for less than 0.5 s, the light illuminates; it goes out by pressing again.
 - b) By pressing the programmed button for more than 0.5 s, fluid brightness regulation will occur. After releasing the button, the brightness level is saved in the memory, and pressing the button shortly later will switch the light on/off to this intensity.
 - c) It is possible to readjust the change in intensity at any time by a long press of the programmed button.
- The actuator remembers the adjusted value even after disconnecting from the power supply.

Light scene function 3

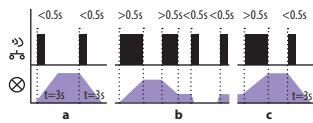

- a) By pressing the programmed button for less than 0.5 s, the light fluidly illuminates for a period of 3 s (at 100% brightness). By pressing the button shortly again, the light will continuously switch off for 3 seconds.
 - b) By pressing the programmed button for more than 0.5 s, fluid brightness regulation will occur. After releasing the button, the brightness level is saved in the memory, and pressing the button shortly later will switch the light on/off to this intensity.
 - c) It is possible to readjust the change in intensity at any time by a long press of the programmed button.
- The actuator remembers the adjusted value even after disconnecting from the power supply.

Function sunrise

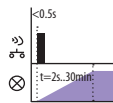

After pressing the programmed button, the light begins to illuminate in the programmed time interval in a range of 2 seconds to 30 minutes.

Function ON/OFF

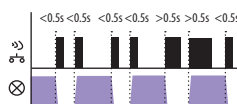

If the light is switched off, pressing the programmed button will switch it on. If the light is switched on, pressing the programmed button will switch it off.

Light scene function 2

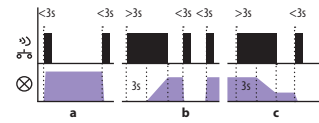

- a) By pressing the programmed button for less than 3 s, the light illuminates; it goes out by pressing again.
 - b) In order to limit undesirable control of brightness, fluid brightness control occurs only by pressing a programmed button for over 3 s. After releasing the button, the brightness level is saved in the memory, and pressing the button shortly later will switch the light on/off to this intensity.
 - c) It is possible to readjust the change in intensity at any time by pressing the programmed button for over 3 s.
- The actuator remembers the adjusted value even after disconnecting from the power supply.

Light scene function 4

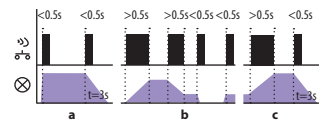

- a) By pressing the programmed button for less than 0.5 s, the light illuminates. By pressing the button shortly again, the light will continuously switch off for 3 seconds (at 100% brightness).
 - b) By pressing the programmed button for more than 0.5 s, fluid brightness regulation will occur. After releasing the button, the brightness level is saved in the memory, and pressing the button shortly later will switch the light on/off to this intensity.
 - c) It is possible to readjust the change in intensity at any time by a long press of the programmed button.
- The actuator remembers the adjusted value even after disconnecting from the power supply.

Function sunset

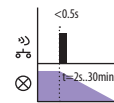

After pressing the programmed button, the light begins to dim in the programmed time interval in a range of 2 seconds to 30 minutes.

Function switch off

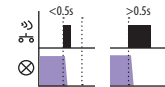

The dimmer output switches off by pressing the button.

Rating of the light source ELKO lighting on dimmers ELKO EP

	LED bulb		LED spot lights			LED panels		LED / RGB strip					
	DLB-E27-806-2K7	DLB-E27-806-5K	DLSL-GU10-350-3K	LSL-GU10-350-3K	LSL-GU10-350-5K	LP-6060-3K	LP-6060-6K	LED strip 7.2W	LED strip 14.4W	LED strip 19.2W	LED strip 28.8W	RGB strip 7.2W	RGB strip 14.4W
RFDSC-71	✓ 21	✓ 21	✓ 45	✓ 25	✓ -	- -	- -	- -	- -	- -	- -	- -	- -
RFDEL-71B	✓ 11	✓ 11	✓ 25	✓ 13	✓ 13	- -	- -	- -	- -	- -	- -	- -	- -
RFDA-73M/RGB	- -	- -	- -	- -	- -	- -	- -	✓ 3x8m	✓ 3x4m	✓ 3x5m	✓ 3x4m	✓ 20m	✓ 10m
RFDAC-71B	- -	- -	- -	- -	- -	✓ 50	✓ 50	- -	- -	- -	- -	- -	- -

WARNING!

May lead to different results based on the state of network cable length and other factors.

This table contains the results of tests that were conducted internally and therefore is ONLY for customers only informative. The products were tested in test laboratories ELKO EP, and therefore the company assumes no responsibility for any imitation test environment.

Inductive and capacitive loads must not be connected simultaneously!

Load capacity:

* Due to the huge amount of type of light sources, the maximum load depends on internal construction of dimmable LED and ESL bulbs and their power factor cos φ, capacity for power factor cos φ=1. The power factor of dimmable LEDs and ESL bulbs ranges from cos φ= 0.95 up to 0.4. An approximate value of maximum load may be obtained by multiplying the load capacity of the dimmer by the power factor of the connected light source.

The communication between the components is wireless at 866–922 MHz (according to country standards/regulations), using the unique RFIO and RFIO2 protocols. Both are proprietary wireless protocols from ELKO EP, which have a completely unique structure. RFIO2 is an extension of the RFIO protocol and allows users to use newly introduced features, such as unit signals (repeater), for selected features. This protocol is fully compatible with the previous version of the protocol (RFIO).

Available frequency for individual territories:

865.15 MHz India

868.1 MHz Russia

868.5 MHz EU, Ukraine, Middle East

916 MHz Australia, New Zealand, America, Israel

Benefits of RFIO:

- Communication is low-energy and reliably transfers small data packets.
- Fees or licenses are not required.
- No overlapping of communication space with unaddressed commands.
- Frequency used does not interfere with Wi-Fi/Bluetooth devices.
- Setting communication between components is not conditional on working with a computer or system.

Benefits of RFIO2:

- Products labeled as “RFIO2” will allow newly set selected components such as unit signals (repeaters).
- For components, you can easily update FW using the RFAF/USB service device.
- Enables communication with RFMD-100 and RFWD-100.
- Data transfer between wireless components takes place in such a way that other receivers within range can help transfer the information (packet) to a remote receiver that is out of reach. It is possible to cover large-scale objects (real estate) and also increase the reliability of transmission in more demanding buildings.
- Backward compatibility with RFIO elements is retained.



1) Surface mounted

Wall mounted or in an installation box with spacing of 65 mm.

RF Touch-W	RFTC-10/G
RFWB-20/G	RFTC-50/G
RFWB-40/G	RFTC-150/G
RFGB-20	RFGB-220
RFGB-40	RFGB-240

2) Flush mounted

RF Touch-B	RFGCR-31
RFDW-71	RFDW-271

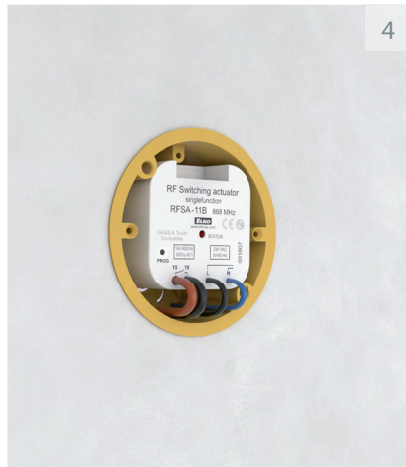
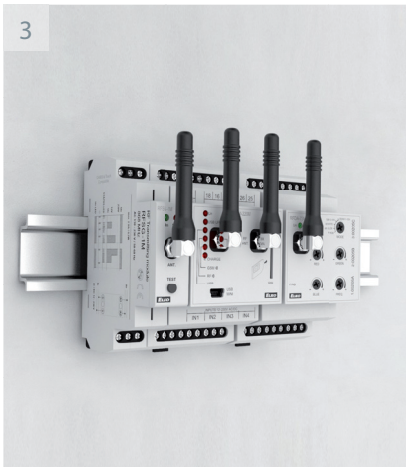

3) DIN Rail mounted

On DIN rail according to EN 60715.

RFSG-1M	RFSA-61M
RFDA-73M/RGB	RFSA-66M
RFDEL-71M	RFSA-66MI
RFSA-166M	

4) Flush mounted (BOX)

RFIM-20B	RFSAI-62B
RFIM-40B	RFJA-32B
RFDAC-71B	RFSE-1B
RFDEL-71B	RFSTI-11B
RFSA-11B	RFTI-10B
RFSA-61B	RFSAI-161B
RFSA-62B	RFSTI-111B



5) Mounted into the cover of appliance

RFDAC-71B	RFJA-32B
RFDEL-71B	RFSAI-161B
RFSA-11B	RFSTI-111B
RFSA-61B	
RFSA-62B	

6) Surface mounted

RFSOU-1	RFWD-100
RFUS-61	RFOWB-20
RFTM-100	RFOSC-61
RFSE-1B	RFWS-100
RFMD-100	

Product dimension

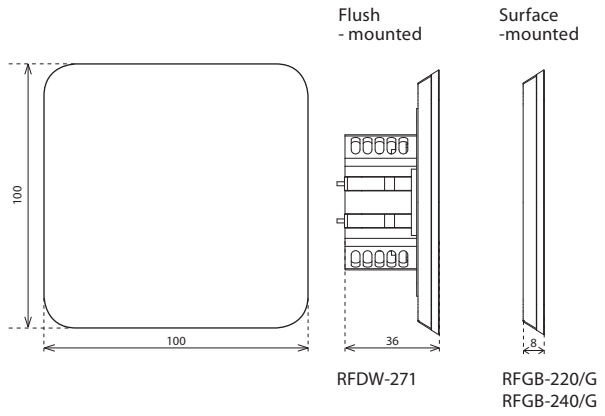
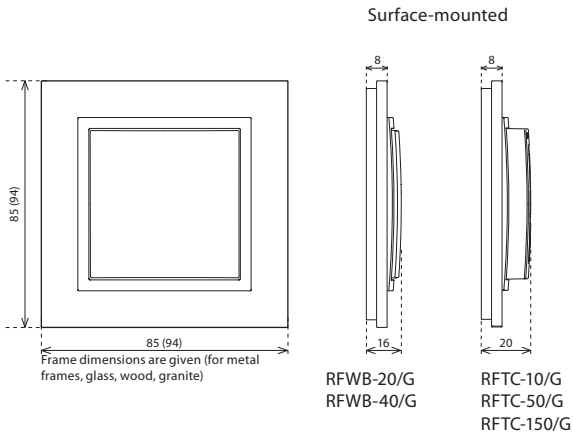
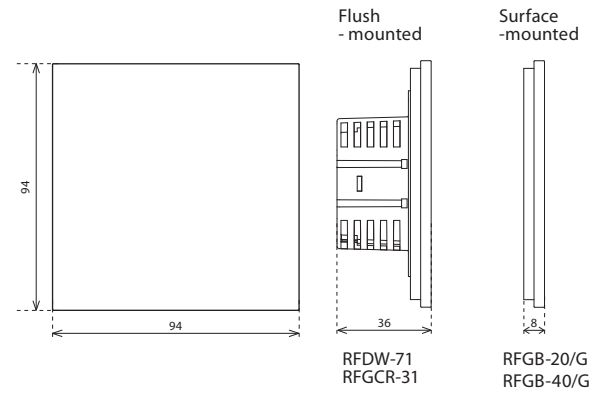
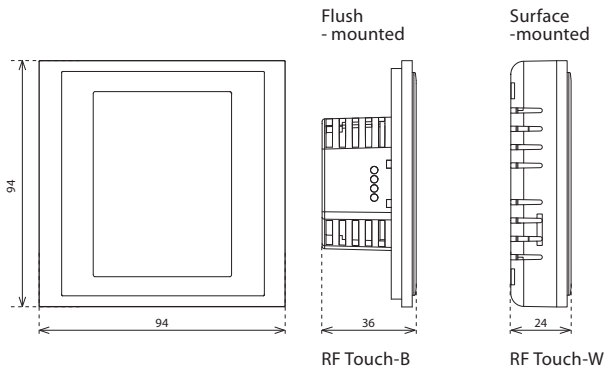

1-MODULE

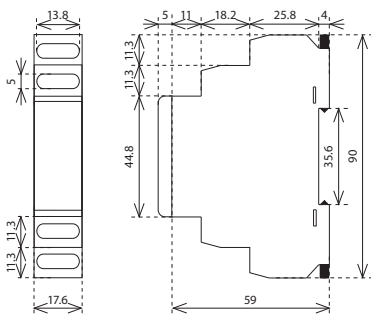

RFSG-1M
RFS-61M

3-MODULE

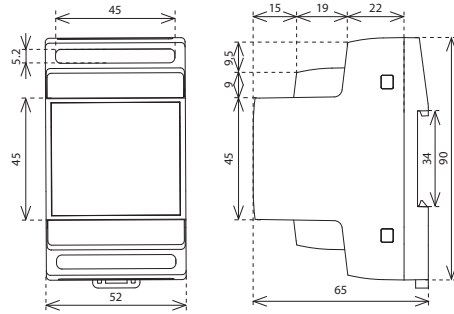

RFS-166M RFD-71M
RFS-66M RFD-73M/RGB

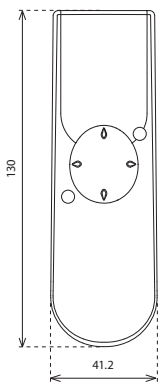
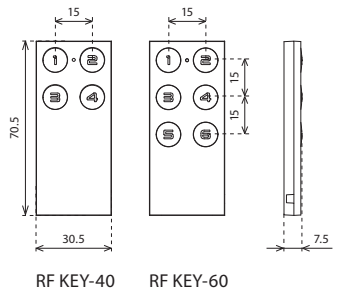

RF Pilot

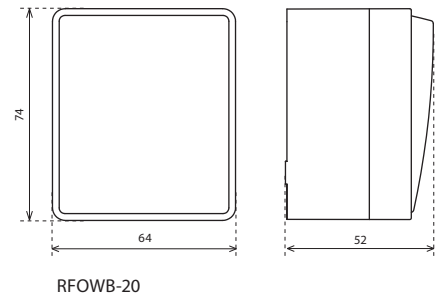
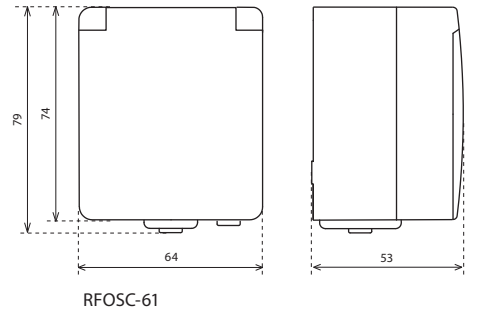
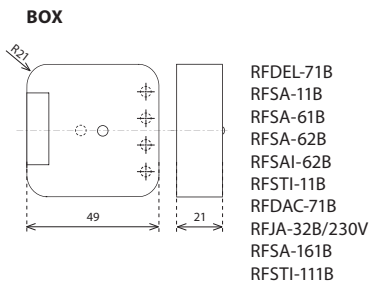
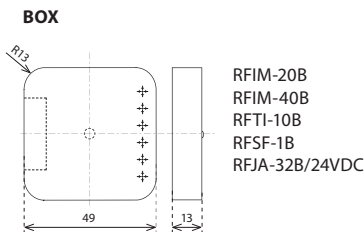

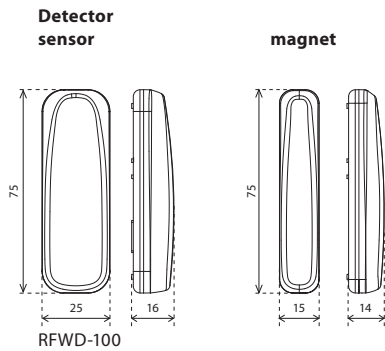
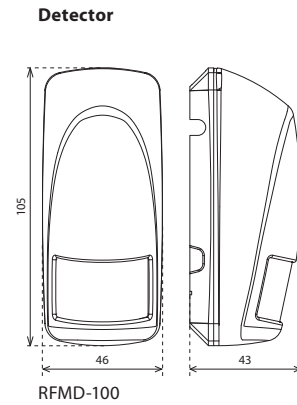
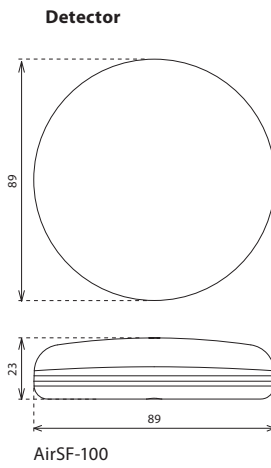
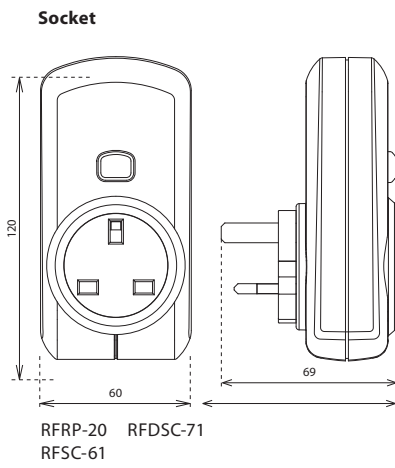
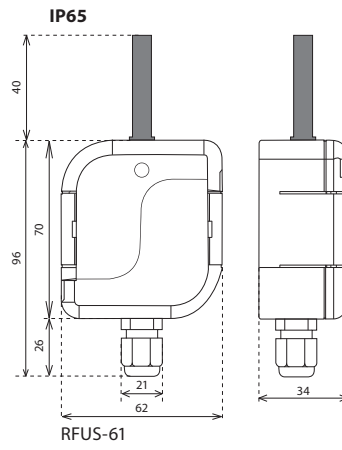
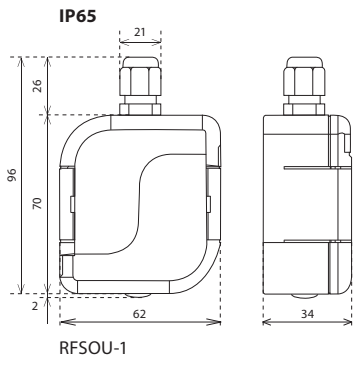

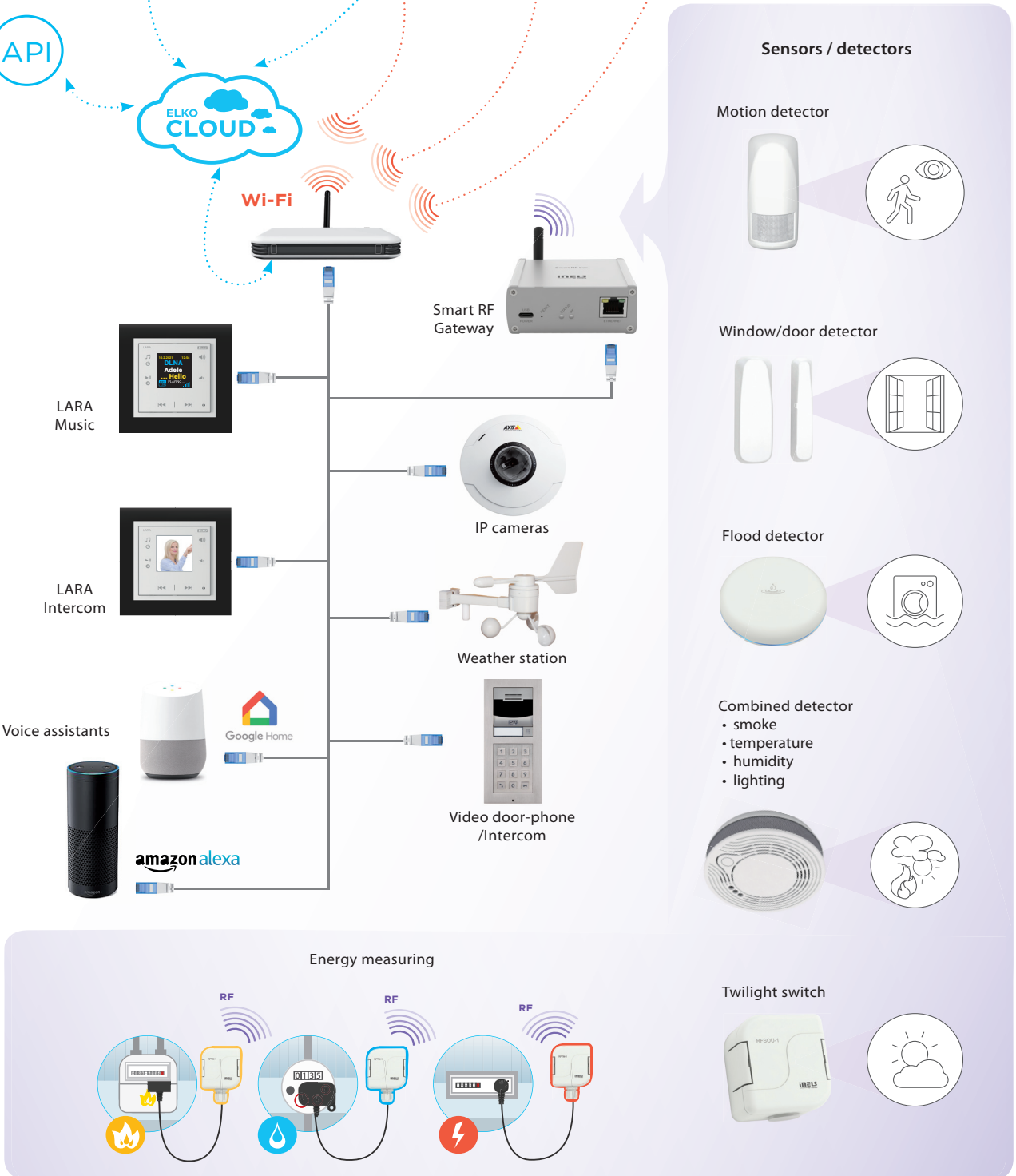
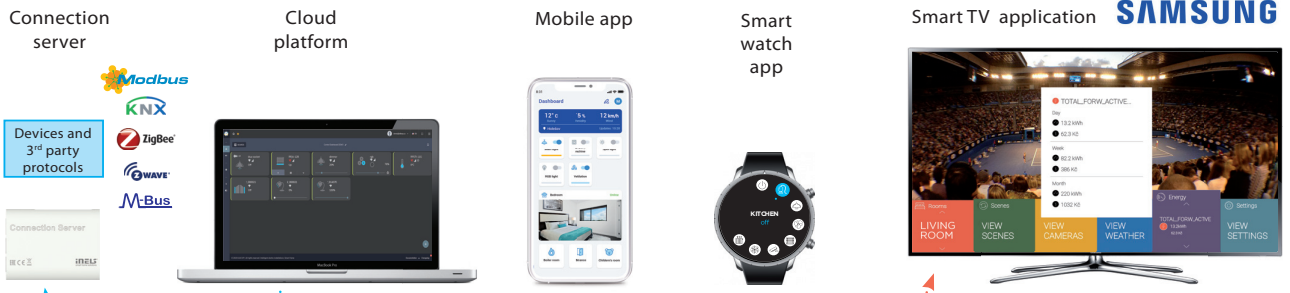

Actuators

Switching socket

Universal dimmer R-L-C-LED-ESL

Switch unit for shutters

Thermovalve

Switch unit 6-channels

Analog controller 0(1)-10 V

Switching socket with increased protection

Switch unit for outdoor use

Controllers

On wall button

Glass touch

Glass touch with dimmer

RF Pilot with display

Key fob

Contact converter

Outdoor 2-buttons controller with increased protection IP 65

Wireless touch unit

Temperature controller

Product groups of the Wireless electro-installation



Controllers



Switching units



Dimmers

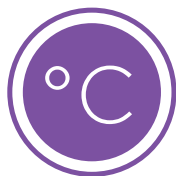

Temperature control



Convertors



Detectors

Frequency	EAN	Type	Supply voltage
868.5 MHz	8595188140379	RFWB-20/G*	1x CR2032
868.5 MHz	8595188140607	RFWB-40/G*	1x CR2032
868.5 MHz	8595188181471	RFOWB-20	1x CR2032
868.5 MHz	8595188176781	RFGB-20/W	2x CR2032
868.5 MHz	8595188176798	RFGB-20/B	2x CR2032
868.5 MHz	8595188176804	RFGB-40/W	2x CR2032
868.5 MHz	8595188176811	RFGB-40/B	2x CR2032
868.5 MHz	8595188176835	RFGB-220/W	2x CR2032
868.5 MHz	8595188176842	RFGB-220/B	2x CR2032
868.5 MHz	8595188176859	RFGB-240/W	2x CR2032
868.5 MHz	8595188176866	RFGB-240/B	2x CR2032
868.5 MHz	8595188159838	RFDW-71/230V/W	230 V AC
868.5 MHz	8595188141789	RFDW-71/230V/B	230 V AC
868.5 MHz	8595188159852	RFDW-71/120V/W	120 V AC
868.5 MHz	8595188144223	RFDW-71/120V/B	120 V AC
868.5 MHz	8595188176958	RFDW-271/W	230 V AC
868.5 MHz	8595188180429	RFDW-271/B	230 V AC
868.5 MHz	8595188180740	RF KEY-40/W	1x CR2032
868.5 MHz	8595188180757	RF KEY-40/B	1x CR2032
868.5 MHz	8595188180764	RF KEY-60/W	1x CR2032
868.5 MHz	8595188180771	RF KEY-60/B	1x CR2032
868.5 MHz	8595188143769	RF Pilot/W	2x 1.5 V AAA
868.5 MHz	8595188145169	RF Pilot/A	2x 1.5 V AAA
868.5 MHz	8595188136839	RFSA-11B/230V	230 V AC
916 MHz	8595188151436	RFSA-11B/120V	120 V AC
868.5 MHz	8595188151399	RFSA-11B/24V	12-24 V AC / DC
868.5 MHz	8595188136242	RFSA-61B/230V	230 V AC
916 MHz	8595188151504	RFSA-61B/120V	120 V AC
868.5 MHz	8595188151467	RFSA-61B/24V	12-24 V AC / DC

Frequency	EAN	Type	Supply voltage
868.5 MHz	8595188142816	RFSA-62B/230V	230 V AC
916 MHz	8595188151832	RFSA-62B/120V	120 V AC
868.5 MHz	8595188151894	RFSA-62B/24V	12 - 24 V AC
868.5 MHz	8595188149990	RFSAI-62B/230V	230 V AC
916 MHz	8595188174947	RFSAI-62B/120V	120 V AC
868.5 MHz	8595188174664	RFJA-32B/230V	230 V AC
916 MHz	8595188174923	RFJA-32B/120V	120 V AC
868.5 MHz	8595188157681	RFJA-32B/24V DC	5 - 24 V DC
868.5 MHz	8595188137003	RFSA-61M/230V	110 - 230 V AC
868.5 MHz	8595188181549	RFSA-61MI/230V	110 - 230 V AC
868.5 MHz	8595188142823	RFSA-66M/230V	110 - 230 V AC
868.5 MHz	8595188152914	RFSA-66M/24V	12-24 V AC / DC
868.5 MHz	8595188181556	RFSA-66MI/230V	110 - 230 V AC
868.5 MHz	8595188181563	RFSA-66MI/24V	12-24 V AC / DC
868.5 MHz	8595188145268	RFUS-61/230V	230 V AC
916 MHz	8595188152570	RFUS-61/120V	120 V AC
868.5 MHz	8595188145602	RFSC-61 French	230 - 250 V AC
868.5 MHz	8595188145626	RFSC-61 Schuko	230 - 250 V AC
868.5 MHz	8595188145442	RFSC-61 British	230 - 250 V AC
868.5 MHz	8595188180627	RFOSC-61	230 - 250 V AC
868.5 MHz	8595188145121	RFDEL-71B/230V	230 V AC
868.5 MHz	8595188152228	RFDEL-71B/120V	120 V AC
868.5 MHz	8595188182058	RFDEL-76M/230V	230 V AC
868.5 MHz	8595188182096	RFDEL-76M/120V	120 V AC
868.5 MHz	8595188142809	RFDAC-71B	110 - 230 V AC
868.5 MHz	8595188148979	RFDEL-71M/230V	230 V AC
868.5 MHz	8595188153041	RFDEL-71M/120V	120 V AC

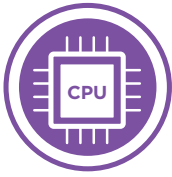

System units



Energy management



Hotel Retrofit



RF sets



Lighting



Accessories



Frequency	EAN	Type	Supply voltage
868.5 MHz	8595188146814	RFDA-73M/RGB	12 - 24 V DC
868.5 MHz	8595188145947	RFDSC-71 French	230 - 250 V AC
868.5 MHz	8595188145954	RFDSC-71 Schuko	230 - 250 V AC
868.5 MHz	8595188145466	RFDSC-71 British	230 - 250 V AC
868.5 MHz	8595188142861	RFTC-10/G***	2x 1.5 V AAA
868.5 MHz	8595188148641	RFTC-50/G**	2x 1.5 V AAA
868.5 MHz	8595188135849	RFSTI-11B/230V	230 V AC
868.5 MHz	8595188152396	RFSTI-11B/120V	120 V AC
868.5 MHz	8595188152419	RFSTI-11B/24V	12 - 24 V AC/DC
868.5 MHz	8595188131759	RFTI-10B	1x CR2477
	8595188110075	TC-0	
	8595188110617	TC-3	
	8595188110082	TC-6	
	8595188110099	TC-12	
	8595188140591	TZ-0	
	8595188110600	TZ-3	
	8595188110594	TZ-6	+ adapter VA80
	8595188110587	TZ-12	+ adapter VA80 + adapter VA80
	8595188181976	TELVA-2 230V, NC	+ adapter VA80
	8595188181969	TELVA-2 /230V, NO	
	8595188181990	TELVA-2 24V, NC	
	8595188181983	TELVA-2 24V NO	
868.5 MHz	8595188139274	RFIM-20B	1x CR2477
868.5 MHz	8595188137188	RFIM-40B	2x CR2032 1x 3.6V LS 14500 Li-SOCI2 AA
868.5 MHz	8595188142847	RFSG-1M	110 - 230 V AC
868.5 MHz	8595188181464	RFWS-100	

Frequency	EAN	Type	Supply voltage
868.5 MHz	8595188148603	RFSF-1B	1x CR2477
868.5 MHz	8595188150095	RFSF-1B+FP-1	1x CR2477
	8595188147064	FP-1	
868.5 MHz	8595188176828	RFSF-100	2x 1.5 V AAA
868.5 MHz	8595188147071	RFSOU-1	2x 1.5 V AAA
868.5 MHz	8595188150293	RFMD-100	2x 1.5 V AA
868.5 MHz	8595188150279	RFWD-100	1x CR 2032
868.5 MHz	8595188143738	RF Touch-B**	100 - 230 V AC
868.5 MHz	8595188131711	RF Touch-W ¹	100-230V AC / 12V DC
868.5 MHz	8595188145107	RFRP-20 French	230 - 250 V AC
868.5 MHz	8595188145473	RFRP-20 Schuko	230 - 250 V AC
868.5 MHz	8595188145480	RFRP-20 British	230 - 250 V AC
868.5 MHz	8595188180443	eLAN-RF-103	5V DC / 0.5A
868.5 MHz	8595188180849	eLAN-RF-Wi-103	5V DC / 1A
868.5 MHz	8595188134576	RFTC-150/G**	2x 1.5 V AAA
868.5 MHz	8595188149341	RFSAI-161B/230V	230 V AC
868.5 MHz	8595188134040	RFSAI-161B/120V	120 V AC
868.5 MHz	8595188149150	RFSTI-111B/230V	230 V AC
868.5 MHz	8595188134095	RFSTI-111B/120V	120 V AC
868.5 MHz	8595188134323	RFSA-166M/230V	110 - 230 V AC
868.5 MHz	8595188145039	RFAF/USB	
	8595188161862	AN-I	
	8595188190121	AN-E	

* white cover / white frame, BASE design
 ** white / white
 *** white / white / white

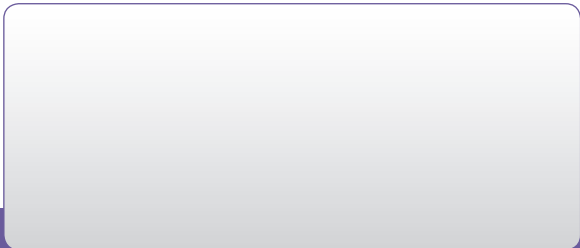
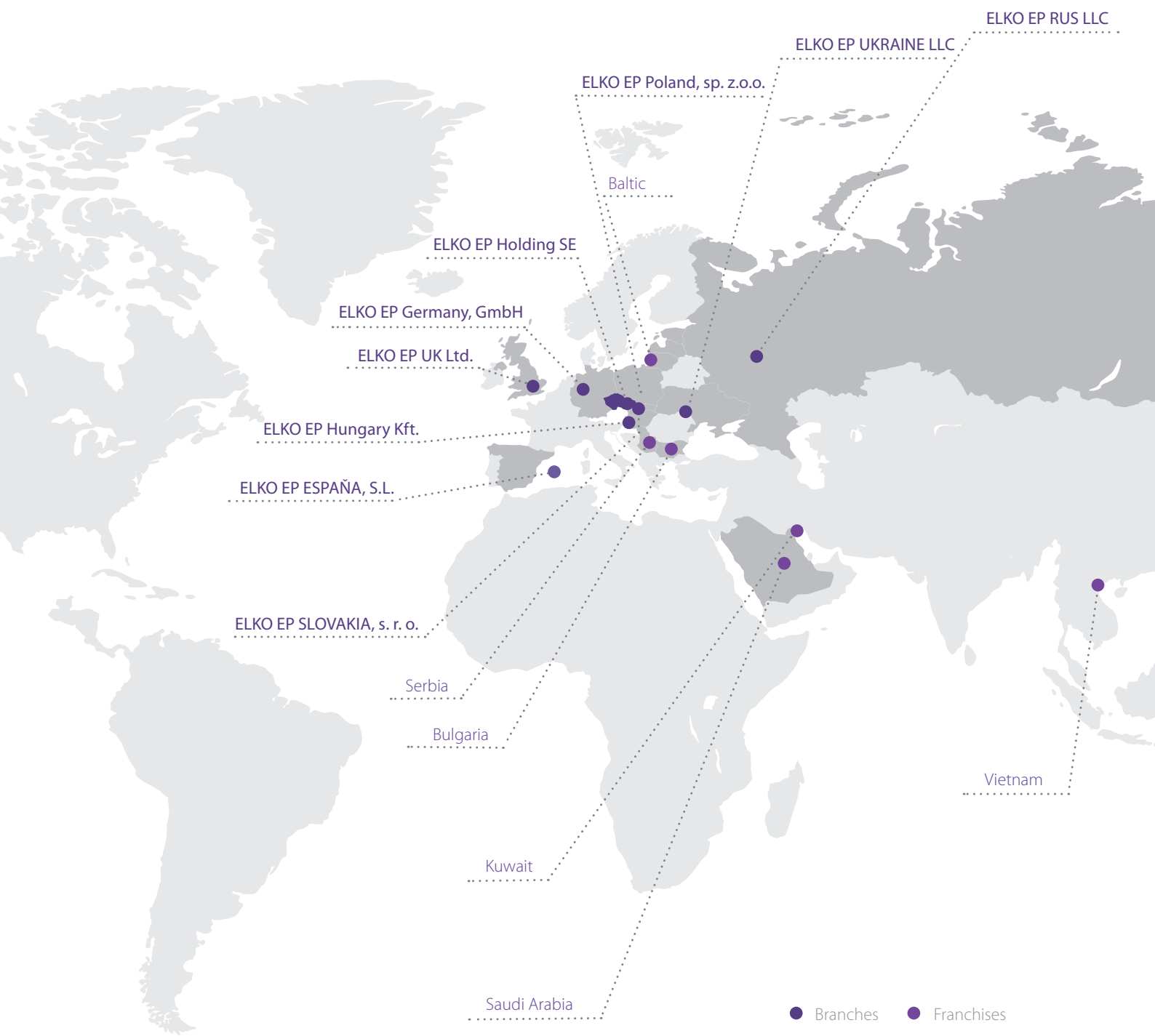

ELKO EP, s.r.o. | Palackeho 493 | 769 01 Holesov, Vsetuly | Czech Republic
 phone: +420 573 514 221 | fax: +420 573 514 227 | elko@elkoep.com | www.elkoep.com

Published: 02/2021 | Modifications or amendments reserved | © Copyright ELKO EP, s.r.o. | 1st edition