

# AirSOU-100 | Twilight sensor



AirSOU-100S      AirSOU-100L  
AirSOU-100NB

Technical parameters	AirSOU-100S	AirSOU-100L	AirSOU-100NB
<b>Photo sensor parameters</b>			
Light measurement range:	1 - 100 000 lx		
Detection angle:	100°		
<b>Power supply</b>			
Battery power:	1x 3.6V LS 14500 Li-SOCl <sub>2</sub> AA		
Battery life by frequency *:			
1x 10 minutes	0.4 years	7.1 years	1.9 years
1x 60 minutes	2.1 years	10.6 years	3.2 years
1x 12 hours	8.5 years	11.7 years	3.6 years
1x 24 hours	9.9 years	11.8 years	3.6 years
External power supply:	5- 12V DC (on terminal)		
Supply voltage tolerance:	+10 %; -15%		
Standby consumption:	0.2 mW		
Transmitting power consumption:	250 mW	150 mW	850 mW
<b>Setting</b>			
Setting:	Using a message from the server, the programming cable		
Battery status view:	message to the server		
<b>Control</b>			
Control:	button (Communication test) Tamper		
<b>Communication</b>			
Protocol:	Sigfox	LoRa	NB-IoT
Transmitter frequency:	RCZ1 868 MHz	868 MHz	LTE Cat NB1**
Range in open space:	Approx. 50 km***	Approx. 10 km***	Approx. 30 km***
Transmission power (max.):	25 mW / 14 dBm	25 mW / 14 dBm	200 mW / 23 dBm
<b>Other parameters</b>			
Working temperature:	-30...+60°C (Pay attention to the operating temperature of batteries)		
Storage temperature:	-30...+70°C		
Operation position:	vertical		
Mounting:	glue / screws		
Protection degree:	IP65		
Dimension with antenna:	158 x 62 x 34 mm	112 x 62 x 34 mm	112 x 62 x 34 mm
Weight:	108 g****	97 g****	108 g****

\* Values are calculated under ideal conditions  
 \*\* Depending on network coverage  
 \*\*\* Multiple frequency bands of B1 / B3 / B5 / B8 / B20 / B28  
 \*\*\*\* Without battery

- Information about the actual light intensity can be used in the task of maintaining a constant illumination in a given space, where it is possible to regulate the intensity of artificial lighting thanks to the contribution of natural lighting from outside, thereby reducing the energy consumption.
- AirSOU-100 can be used not only in residential projects, but also in commercial office projects or production and warehouse or production halls.
- The AirSOU-100 is recommended to be installed so that the light sensing sensor is facing downwards and not exposed to direct light.
- The scanning range is 1 - 100,000 lux.
- Data is sent to the server from which it can be subsequently displayed as a smartphone, application, or Cloud notification.
- Battery power can be sent to the server when it is powered by a battery.
- The AirSOU-100 is supplied in an IP65 enclosure and can be installed in an outdoor environment.

## Device description

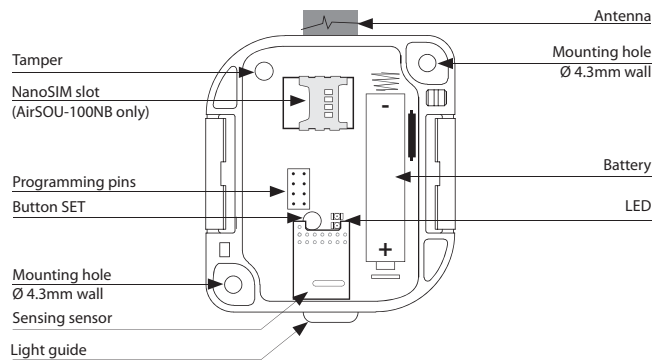

## Function

After inserting the batteries, the sensor sends an introductory message containing the measured light intensity. The sensor scans the light intensity every 2 minutes. After that, it sends a data message of measured values every 60 minutes. In the event of a sudden change in light intensity, it sends the data message immediately.